



# Industrial Analog Current/Voltage OUTPUT DRIVER

## FEATURES

- USER-SELECTABLE: Voltage or Current Output
- +40V SUPPLY VOLTAGE
- $V_{OUT}$ :  $\pm 10V$  (up to  $\pm 17.5V$  at  $\pm 20V$  supply)
- $I_{OUT}$ :  $\pm 20mA$  (linear up to  $\pm 24mA$ )
- SHORT- OR OPEN-CIRCUIT FAULT INDICATOR PIN
- NO CURRENT SHUNT REQUIRED
- OUTPUT DISABLE FOR SINGLE INPUT MODE
- THERMAL PROTECTION
- OVER-CURRENT PROTECTION
- SEPARATE DRIVER AND RECEIVER CHANNELS
- DESIGNED FOR TESTABILITY

## APPLICATIONS

- PLC OUTPUT PROGRAMMABLE DRIVER
- INDUSTRIAL CROSS-CONNECTORS
- INDUSTRIAL HIGH-VOLTAGE I/O
- 3-WIRE-SENSOR CURRENT OR VOLTAGE OUTPUT
- $\pm 10V$  2- AND 4-WIRE VOLTAGE OUTPUT

Patents Pending

## DESCRIPTION

The XTR300 is a complete output driver for industrial and process control applications. The output can be configured as current or voltage by the digital I/V select pin. No external shunt resistor is required. Only external gain-setting resistors and a loop compensation capacitor are required.

The separate driver and receiver channels provide flexibility. The Instrumentation Amplifier (IA) can be used for remote voltage sense or as a high-voltage, high-impedance measurement channel. In voltage output mode, a copy of the output current is provided, allowing calculation of load resistance.

The digital output selection capability, together with the error flags and monitor pins, make remote configuration and troubleshooting possible. Fault conditions on the output and on the IA input as well as over-temperature conditions are indicated by the error flags. The monitoring pins provide continuous feedback about load power or impedance. For additional protection, the maximum output current is limited and thermal protection is provided.

Digital communication like HART® can be modulated onto the input signal. The receive signal applied to the output can be detected at the monitor pins in both current and voltage output modes. In addition to HART communication, the device offers system or sensor configuration through the signal connector.

The XTR300 is specified over the  $-40^{\circ}C$  to  $+85^{\circ}C$  industrial temperature range and for supply voltage up to 40V.

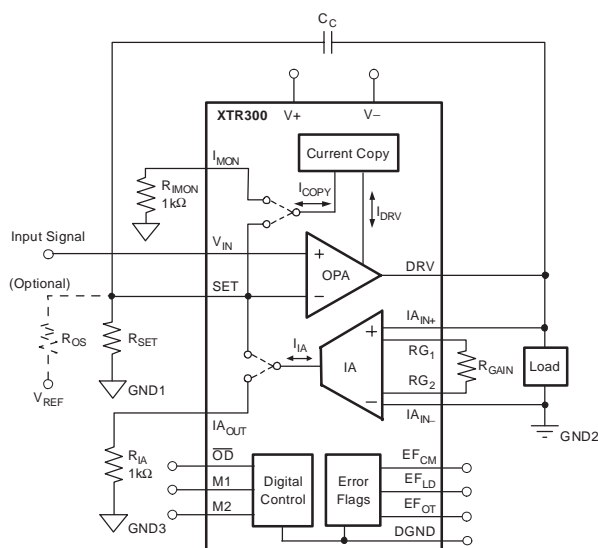

Figure 1. XTR300 Basic Diagram



Please be aware that an important notice concerning availability, standard warranty, and use in critical applications of Texas Instruments semiconductor products and disclaimers thereto appears at the end of this data sheet.

HART is a registered trademark of the HART Communication Foundation.

All other trademarks are the property of their respective owners.

### ABSOLUTE MAXIMUM RATINGS(1)

Supply Voltage	+44V
Signal Input Terminals	
Voltage(2)	(V-) – 0.5V to (V+) + 0.5V
Current(2)	±25mA
DGND	±25mA
Output Short Circuit(3)	Continuous
Operating Temperature	–55°C to +125°C
Storage Temperature	–55°C to +125°C
Junction Temperature	+150°C
ESD Rating	
Human Body Model	2000V
Charged Device Model	1000V

- (1) Stresses above these ratings may cause permanent damage. Exposure to absolute maximum conditions for extended periods may degrade device reliability. These are stress ratings only, and functional operation of the device at these or any other conditions beyond those specified is not supported.
- (2) Input terminals are diode-clamped to the power-supply rails. Input signals that can swing more than 0.5V beyond the supply rails should be current limited.
- (3) See the *Driver Output Disable* section in Application Information section for thermal protection.

### PIN CONFIGURATION

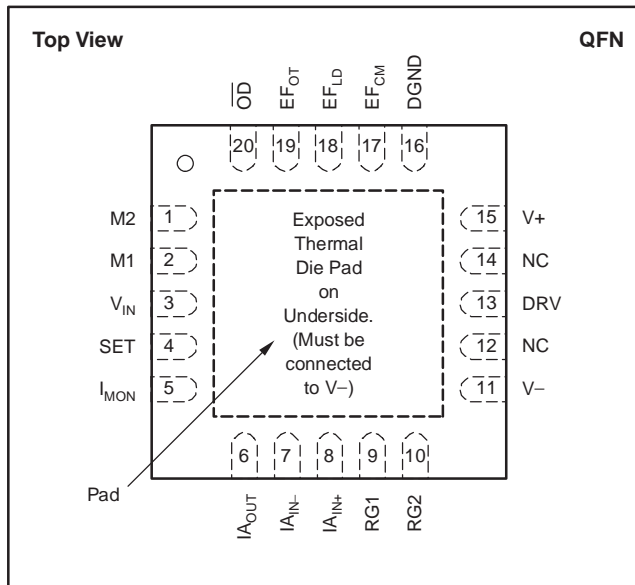

This integrated circuit can be damaged by ESD. Texas Instruments recommends that all integrated circuits be handled with appropriate precautions. Failure to observe proper handling and installation procedures can cause damage.

ESD damage can range from subtle performance degradation to complete device failure. Precision integrated circuits may be more susceptible to damage because very small parametric changes could cause the device not to meet its published specifications.

### ORDERING INFORMATION(1)

PRODUCT	PACKAGE-LEAD	PACKAGE DESIGNATOR	PACKAGE MARKING
XTR300	QFN-20 (5mm x 5mm)	RGW	XTR300

- (1) For the most current package and ordering information, see the Package Option Addendum at the end of this document, or see the TI web site at [www.ti.com](http://www.ti.com).

### PIN ASSIGNMENTS

PIN	NAME	FUNCTION
1	M2	Mode Input
2	M1	Mode Input
3	V <sub>IN</sub>	Noninverting Signal Input
4	SET	Input for Gain Setting; Inverting Input
5	I <sub>MON</sub>	Current Monitor Output
6	I <sub>AOUT</sub>	Instrumentation Amplifier Signal Output
7	I <sub>AIN-</sub>	Instrumentation Amplifier Inverting Input
8	I <sub>AIN+</sub>	Instrumentation Amplifier Noninverting Input
9	RG1	Instrumentation Amplifier Gain Resistor
10	RG2	Instrumentation Amplifier Gain Resistor
11	V-	Negative Power Supply
12	NC	No Internal Connection
13	DRV	Operational Amplifier Output
14	NC	No Internal Connection
15	V+	Positive Power Supply
16	DGND	Ground for Digital I/O
17	E <sub>FCM</sub>	Error Flag for Common-Mode Over-Range, Active Low
18	E <sub>FLD</sub>	Error Flag for Load Error, Active Low
19	E <sub>FOT</sub>	Error Flag for Over Temperature, Active Low
20	OD	Output Disable, Disabled Low
Pad	Pad	Exposed thermal pad must be connected to V-

**ELECTRICAL CHARACTERISTICS: VOLTAGE OUTPUT MODE**

**Boldface** limits apply over the temperature range,  $T_A = -40^{\circ}\text{C}$  to  $+85^{\circ}\text{C}$ .

All specifications at  $T_A = +25^{\circ}\text{C}$ ,  $V_S = \pm 20\text{V}$ ,  $R_{LOAD} = 800\Omega$ ,  $R_{SET} = 2\text{k}\Omega$ ,  $R_{OS} = 2\text{k}\Omega$ ,  $V_{REF} = 4\text{V}$ ,  $R_{GAIN} = 10\text{k}\Omega$ , Input Signal Span 0V to 4V, and  $C_C = 100\text{pF}$ , unless otherwise noted.

PARAMETER	CONDITION	XTR300			UNITS
		MIN	TYP	MAX	
<b>OFFSET VOLTAGE</b> Offset Voltage, RTI <b>vs Temperature</b> vs Power Supply	$V_{OS}$ $dV_{OS}/dT$ PSRR		$\pm 0.4$ $\pm 1.6$ $\pm 0.2$	$\pm 1.9$ $\pm 6$ $\pm 10$	mV $\mu\text{V}/^{\circ}\text{C}$ $\mu\text{V}/\text{V}$
<b>INPUT VOLTAGE RANGE</b> Nominal Setup for $\pm 10\text{V}$ Output Input Voltage For Linear Operation	See Figure 2	(V-) + 3V		(V+) - 3V	V
<b>NOISE</b> Voltage Noise, $f = 0.1\text{Hz}$ to $10\text{Hz}$ , RTI Voltage Noise Density, $f = 1\text{kHz}$ , RTI	$e_n$		3 40		$\mu\text{V}_{PP}$ $\text{nV}/\sqrt{\text{Hz}}$
<b>OUTPUT</b> <b>Voltage Output Swing from Rail</b> Gain Nonlinearity <b>vs Temperature</b> Gain Error <b>vs Temperature</b> Output Impedance, $dV_{DRV}/dI_{DRV}$ <b>Output Leakage Current While Output Disabled</b> <b>Short-Circuit Current</b> Capacitive Load Drive Rejection of Voltage Difference between GND1 and GND2, RTO	$I_{DRV} \leq 15\text{mA}$  $I_B$  $I_{SC}$ $C_{LOAD}$	$(V-) + 3\text{V}$   $\text{Pin } \overline{\text{OD}} = \text{L}(1)$ $C_C = 10\text{nF}, R_C = 15^{(2)}$	$\pm 0.01$ $\pm 0.1$ $\pm 0.04$ $\pm 0.2$ 7 $\pm 15$ 1 130	$(V+) - 3$ $\pm 0.1$ $\pm 1$ $\pm 1$ $\pm 1$ 30 $\pm 20$ $\pm 24$	V %FS $\text{ppm}/^{\circ}\text{C}$ %FS $\text{ppm}/^{\circ}\text{C}$ m $\Omega$ nA mA $\mu\text{F}$ dB
<b>FREQUENCY RESPONSE</b> Bandwidth Slew Rate <sup>(2)</sup>  Settling Time <sup>(2)(3)</sup> , 0.1%, Small Signal Overload Recovery Time	$-3\text{dB}$ SR SR	G = 5  $C_C = 10\text{nF}, C_L = 1\mu\text{F}, R_C = 15\Omega$ $V_{DRV} = \pm 1\text{V}$ 50% Overdrive	300 1 0.015 8 12		kHz V/ $\mu\text{s}$ V/ $\mu\text{s}$ $\mu\text{s}$ $\mu\text{s}$

- (1) Output leakage includes input bias current of INA.
- (2) Refer to *Driving Capacitive Loads* section in Application Information.
- (3)  $8\mu\text{s}$  plus number of chopping periods. See Application Information section, *Internal Current Sources and Settling Time*.

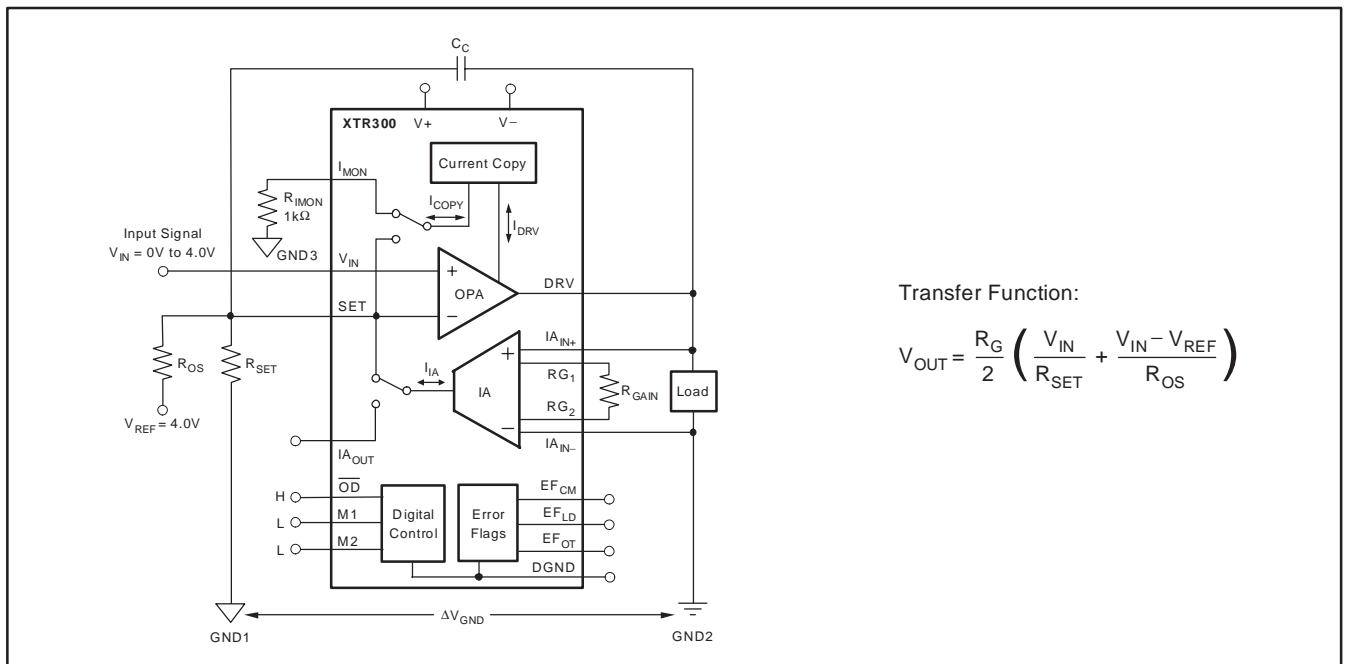

**Figure 2. Standard Circuit for Voltage Output Mode**



**ELECTRICAL CHARACTERISTICS: OPERATIONAL AMPLIFIER (OPA)**
**Boldface** limits apply over the temperature range,  $T_A = -40^{\circ}\text{C}$  to  $+85^{\circ}\text{C}$ .

 All specifications at  $T_A = +25^{\circ}\text{C}$ ,  $V_S = \pm 20\text{V}$ ,  $R_{LOAD} = 800\Omega$ , unless otherwise noted.

PARAMETER	CONDITION	XTR300			UNITS
		MIN	TYP	MAX	
<b>OFFSET VOLTAGE</b> Offset Voltage, RTI <b>Drift</b> vs Power Supply	$V_{OS}$ $dV_{OS}/dT$ PSRR $I_{DRV} = 0\text{A}$ $V_S = \pm 5\text{V}$ to $\pm 22\text{V}$		$\pm 0.4$ <b><math>\pm 1.5</math></b> $\pm 0.2$	$\pm 1.8$ $\pm 5$	mV $\mu\text{V}/^{\circ}\text{C}$ $\mu\text{V}/\text{V}$
<b>INPUT VOLTAGE RANGE</b> Common-Mode Voltage Range Common-Mode Rejection Ratio	$V_{CM}$ CMRR $(V-) + 3\text{V} < V_{CM} < (V+) - 3\text{V}$	$(V-) + 3$ 100	126	$(V+) - 3$	V dB
<b>INPUT BIAS CURRENT</b> Input Bias Current Input Offset Current	$I_B$ $I_{OS}$		$\pm 20$ $\pm 0.3$	$\pm 35$ $\pm 10$	nA nA
<b>INPUT IMPEDANCE</b> Differential Common-Mode			$10^8 \parallel 5$ $10^8 \parallel 5$		$\Omega \parallel \text{pF}$ $\Omega \parallel \text{pF}$
<b>OPEN-LOOP GAIN</b> Open-Loop Voltage Gain	$A_{OL}$ $(V-) + 3\text{V} < V_{DRV} < (V+) - 3\text{V}$ , $I_{DRV} = \pm 24\text{mA}$	100	126		dB
<b>OUTPUT</b> Voltage Output Swing from Rail Short-Circuit Current Output Leakage Current While Output Disabled	$I_{LIMIT}$ $I_{LIMIT}$ $I_{LEAK\_DRV}$ $I_{DRV} = \pm 24\text{mA}$ M2 = High M2 = Low Pin $\overline{OD} = L$	$(V-) + 3$ $\pm 25.5$ $\pm 16$	$\pm 32$ $\pm 20$ 10	$(V+) - 3$ $\pm 38.5$ $\pm 24$	V mA mA pA
<b>FREQUENCY RESPONSE</b> Gain-Bandwidth Product Slew Rate	GBW SR G = 1		2 1		MHz V/ $\mu\text{s}$

### ELECTRICAL CHARACTERISTICS: INSTRUMENTATION AMPLIFIER (IA)

**Boldface** limits apply over the temperature range,  $T_A = -40^{\circ}\text{C}$  to  $+85^{\circ}\text{C}$ .

All specifications at  $T_A = +25^{\circ}\text{C}$ ,  $V_S = \pm 20\text{V}$ ,  $R_{IA} = 2\text{k}\Omega$ , and  $R_{GAIN} = 2\text{k}\Omega$ , unless otherwise noted. See Figure 4.

PARAMETER	CONDITION	XTR300			UNITS
		MIN	TYP	MAX	
<b>OFFSET VOLTAGE</b>					
Offset Voltage, RTI	$I_{DRV} = 0\text{A}$		$\pm 0.7$	$\pm 2.7$	mV
<b>vs Temperature</b>			$\pm 2.4$	$\pm 10$	$\mu\text{V}/^{\circ}\text{C}$
<b>vs Power Supply</b>	$V_S = \pm 5\text{V}$ to $\pm 22\text{V}$		$\pm 0.8$	$\pm 10$	$\mu\text{V}/\text{V}$
<b>INPUT VOLTAGE RANGE</b>					
Common-Mode Voltage Range	RTI	$(V-) + 3$		$(V+) - 3$	V
Common-Mode Rejection Ratio		100	130		dB
<b>INPUT BIAS CURRENT</b>					
Input Bias Current			$\pm 20$	$\pm 35$	nA
Input Offset Current			$\pm 1$	$\pm 10$	nA
<b>INPUT IMPEDANCE</b>					
Differential			$10^8 \parallel 5$		$\Omega \parallel \text{pF}$
Common-Mode			$10^8 \parallel 5$		$\Omega \parallel \text{pF}$
<b>TRANSCONDUCTANCE (Gain)</b>					
Transconductance Error	$I_{AOUT} = 2 (I_{AIN+} - I_{AIN-})/R_{GAIN}$ $I_{AOUT} = \pm 2.4\text{mA}$ , $(V-) + 3\text{V} < V_{IAOUT} < (V+) - 3\text{V}$		$\pm 0.04$	$\pm 0.1$	%FS
<b>vs Temperature</b>			$\pm 0.2$		$\text{ppm}/^{\circ}\text{C}$
Linearity Error	$(V-) + 3\text{V} < V_{IAOUT} < (V+) - 3\text{V}$		$\pm 0.01$	$\pm 0.1$	%FS
Input Bias Current to G1, G2			$\pm 20$		nA
Input Offset Current to G1, G2(1)			$\pm 1$		nA
<b>OUTPUT</b>					
Output Swing to the Rail	$I_{AOUT} = \pm 2.4\text{mA}$	$(V-) + 3$		$(V+) - 3$	V
Output Impedance	$I_{AOUT} = \pm 2.4\text{mA}$		600		$\text{M}\Omega$
Short-Circuit Current	M2 = High		$\pm 7.2$		mA
	M2 = Low		$\pm 4.5$		mA
<b>FREQUENCY RESPONSE</b>					
Gain-Bandwidth Product	GBW	$G = 1$ , $R_{GAIN} = 10\text{k}\Omega$ , $R_{IA} = 5\text{k}\Omega$		1	MHz
Slew Rate	SR	$G = 1$ , $R_{GAIN} = 10\text{k}\Omega$ , $R_{IA} = 5\text{k}\Omega$		1	$\text{V}/\mu\text{s}$
Settling Time(2), 0.1%		$I_{AOUT} = \pm 40\mu\text{A}$ , $R_{GAIN} = 10\text{k}\Omega$ , $R_{IA} = 5\text{k}\Omega$ , $C_L = 100\text{pF}$		6	$\mu\text{s}$
Overload Recovery Time, 50%		$R_{GAIN} = 10\text{k}\Omega$ , $R_{IA} = 15\text{k}\Omega$ , $C_L = 100\text{pF}$		10	$\mu\text{s}$

(1) See Typical Characteristics curve.

(2)  $6\mu\text{s}$  plus number of chopping periods. See Application Information section, *Internal Current Sources and Settling Time*.

### ELECTRICAL CHARACTERISTICS: CURRENT MONITOR

**Boldface** limits apply over the temperature range,  $T_A = -40^{\circ}\text{C}$  to  $+85^{\circ}\text{C}$ .

All specifications at  $T_A = +25^{\circ}\text{C}$ ,  $V_S = \pm 20\text{V}$ , unless otherwise noted. See Figure 4.

PARAMETER	CONDITION	XTR300			UNITS
		MIN	TYP	MAX	
<b>OUTPUT</b>					
Offset Current	$I_{DRV} = 0\text{A}$		$\pm 30$	$\pm 100$	nA
<b>vs Temperature</b>			$\pm 0.06$		$\text{nA}/^{\circ}\text{C}$
<b>vs Power Supply</b>	$V_S = \pm 5\text{V}$ to $\pm 22\text{V}$		$\pm 0.1$	$\pm 10$	$\text{nA}/\text{V}$
Monitor Output Swing to the Rail	$I_{MON} = \pm 2.4\text{mA}$	$(V-) + 3$		$(V+) - 3$	V
Monitor Output Impedance	$I_{MON} = \pm 2.4\text{mA}$		200		$\text{M}\Omega$
<b>MONITOR CURRENT GAIN</b>					
Current Gain Error	$I_{MON} = I_{DRV}/10$ $I_{DRV} = \pm 24\text{mA}$		$\pm 0.04$	$\pm 0.12$	%FS
<b>vs Temperature</b>	$I_{DRV} = \pm 24\text{mA}$		$\pm 3.6$		$\text{ppm}/^{\circ}\text{C}$
Linearity Error	$I_{DRV} = \pm 24\text{mA}$		$\pm 0.1$	$\pm 0.1$	%FS
<b>vs Temperature</b>	$I_{DRV} = \pm 24\text{mA}$		$\pm 1.5$		$\text{ppm}/^{\circ}\text{C}$

**ELECTRICAL CHARACTERISTICS**

**Boldface** limits apply over the temperature range,  $T_A = -40^{\circ}\text{C}$  to  $+85^{\circ}\text{C}$ .

All specifications at  $T_A = +25^{\circ}\text{C}$ ,  $V_S = \pm 20\text{V}$ , unless otherwise noted. See Figure 4.

PARAMETER	CONDITION	XTR300			UNITS
		MIN	TYP	MAX	
<b>POWER SUPPLY</b>					
Specified Voltage Range	$V_S$	$\pm 5$		$\pm 20$	V
Operating Voltage Range		$\pm 5$		$\pm 22$	V
Quiescent Current	$I_{DRV} = I_{AOUT} = 0\text{A}$		1.8	2.3	mA
<b>Over Temperature</b>				<b>2.8</b>	<b>mA</b>
<b>TEMPERATURE RANGE</b>					
Specified Temperature Range		-40		+85	$^{\circ}\text{C}$
Operating Temperature Range		-55		+125 <sup>(1)</sup>	$^{\circ}\text{C}$
Storage Temperature Range		-55		+125	$^{\circ}\text{C}$
Thermal Resistance					
Junction-to-Case	$\theta_{JC}$		6		$^{\circ}\text{C}/\text{W}$
Junction-to-Ambient	$\theta_{JA}$		38		$^{\circ}\text{C}/\text{W}$
<b>THERMAL FLAG (EF<sub>OT</sub>) Output</b>					
Alarm (EF <sub>OT</sub> pin LOW)			140		$^{\circ}\text{C}$
Return to Normal Operation (EF <sub>OT</sub> pin HIGH)			125		$^{\circ}\text{C}$
<b>DIGITAL INPUTS (M1, M2, <math>\overline{\text{OD}}</math>)</b>					
$V_{IL}$ Low-Level Input Voltage			$\leq 0.8$		V
$V_{IH}$ High-Level Input Voltage			$\geq 1.4$		V
Input Current			$\pm 1$		$\mu\text{A}$
<b>DIGITAL OUTPUTS (EF<sub>LD</sub>, EF<sub>CM</sub>, EF<sub>OT</sub>)</b>					
$I_{OH}$ High-Level Leakage Current (Open-Drain)			-1.2		$\mu\text{A}$
$V_{OL}$ Low-Level Output Voltage	$I_{OL} = 5\text{mA}$		0.8		V
$V_{OL}$ Low-Level Output Voltage	$I_{OL} = 2.8\text{mA}$		0.4		V
<b>DIGITAL GROUND PIN</b>					
Current Input	$(V-) \leq \text{DGND} \leq (V+) - 7\text{V}$ $M1 = M2 = L, \overline{\text{OD}} = H, \text{All Digital Outputs H}$		-25		$\mu\text{A}$

(1) EF<sub>OT</sub> not connected with  $\overline{\text{OD}}$ .

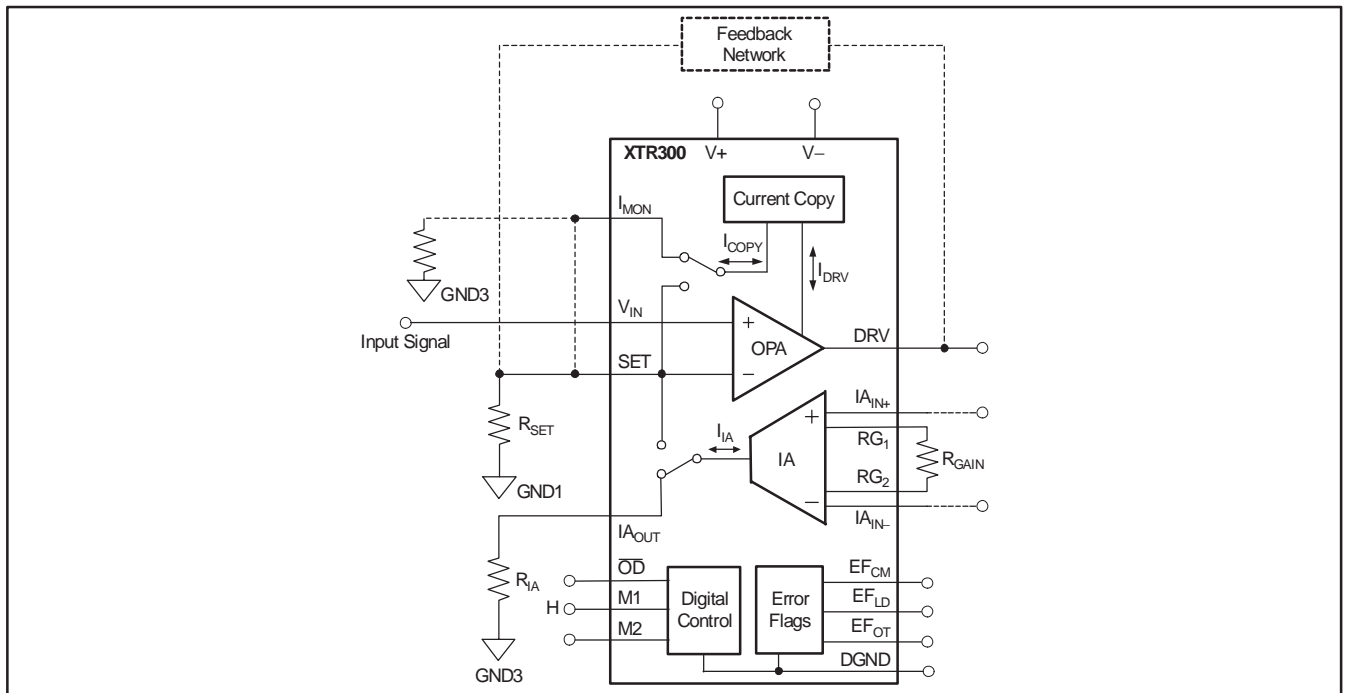

**Figure 4. Standard Circuit for Current Output Mode**

### TYPICAL CHARACTERISTICS

At  $T_A = +25^\circ\text{C}$  and  $V+ = \pm 20\text{V}$ , unless otherwise noted.

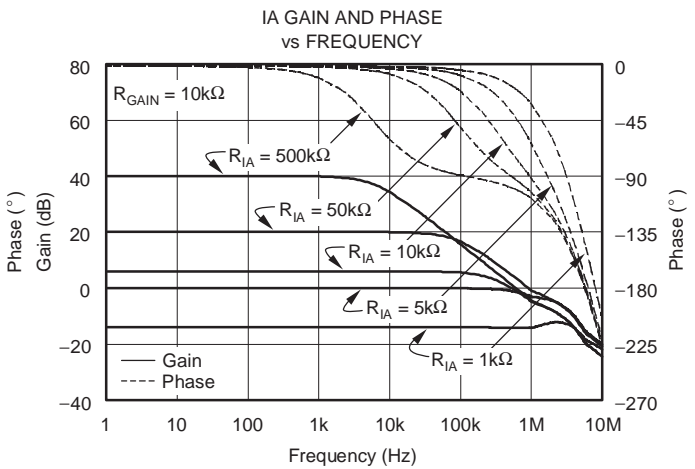
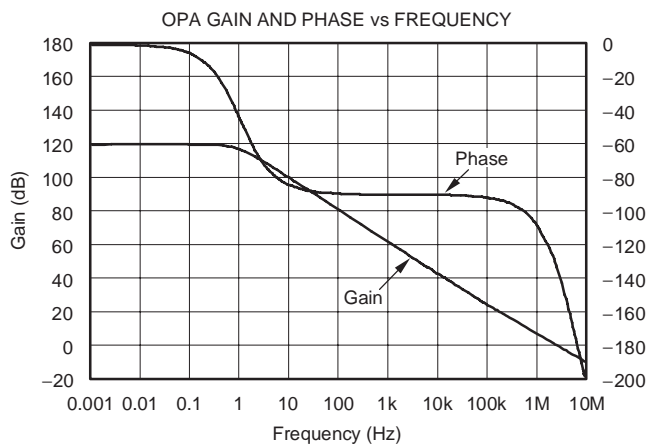
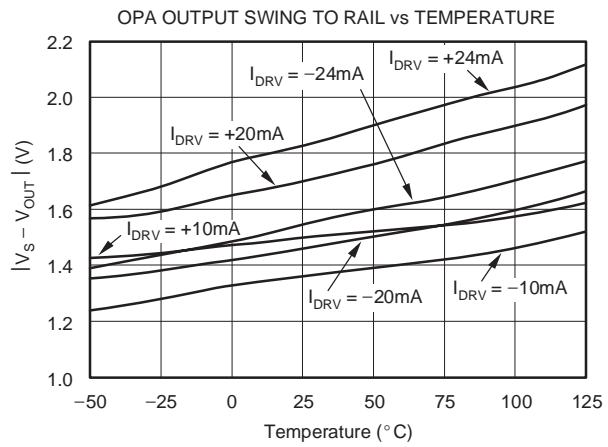
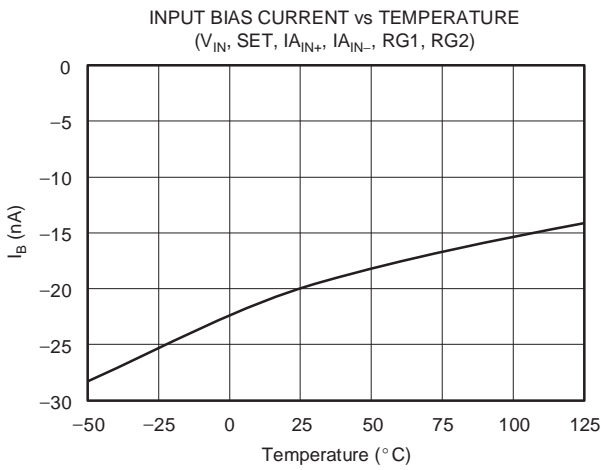
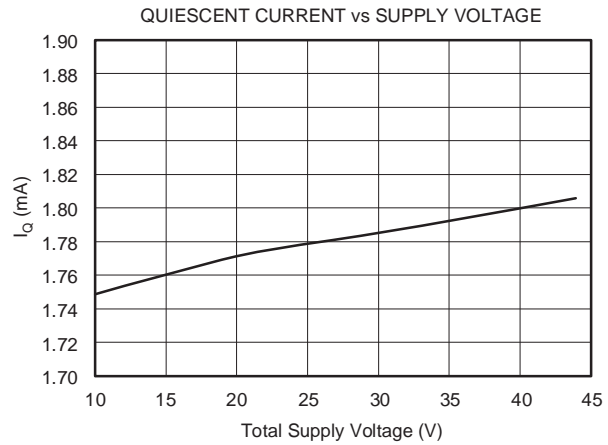
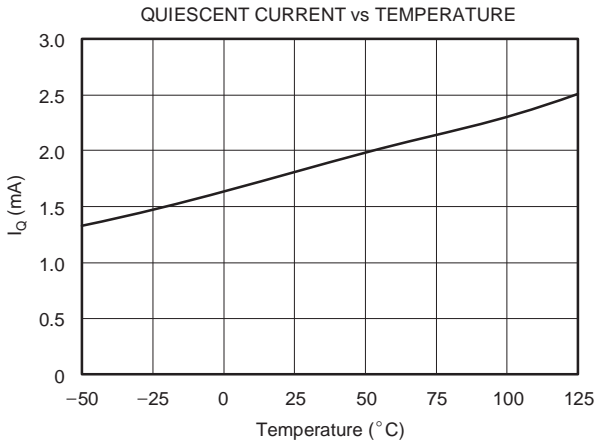



**TYPICAL CHARACTERISTICS (continued)**

At  $T_A = +25^\circ\text{C}$  and  $V_+ = \pm 20\text{V}$ , unless otherwise noted.

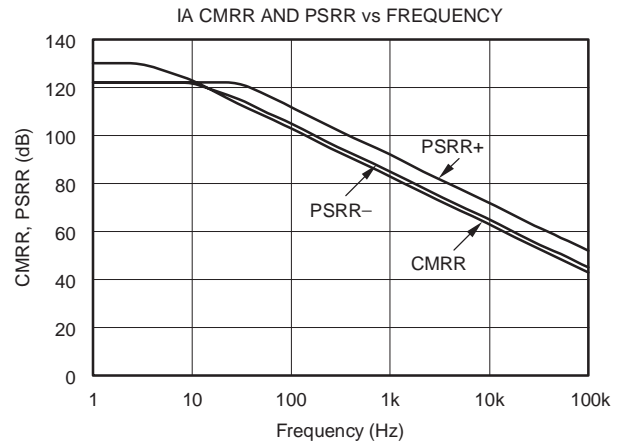
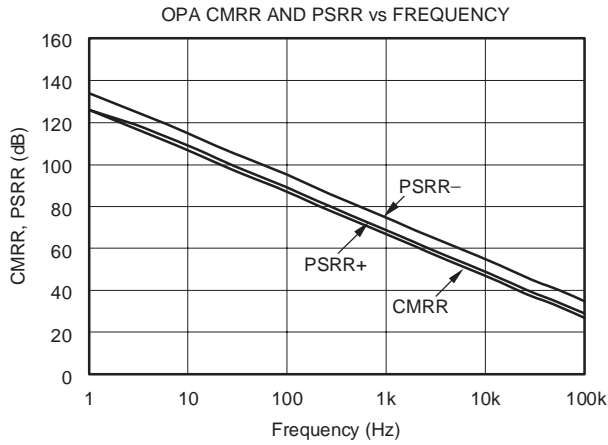

SMALL-SIGNAL STEP RESPONSE  
CURRENT MODE

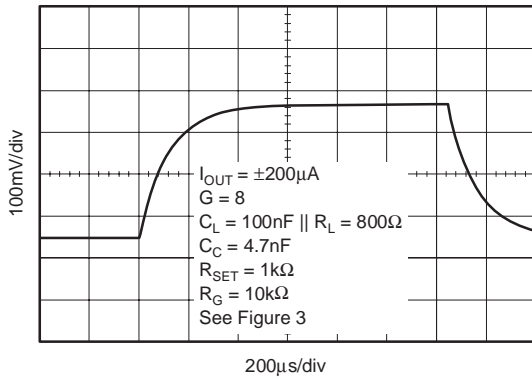

LARGE-SIGNAL STEP RESPONSE  
CURRENT MODE

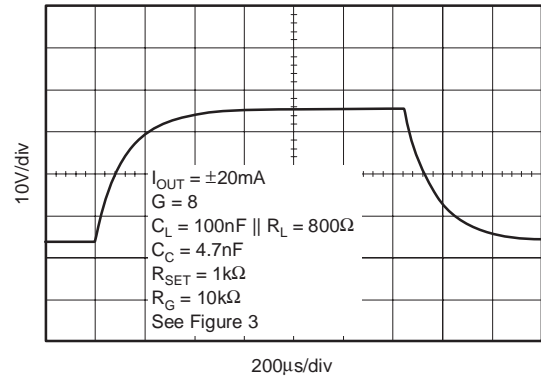

SMALL-SIGNAL STEP RESPONSE  
VOLTAGE MODE

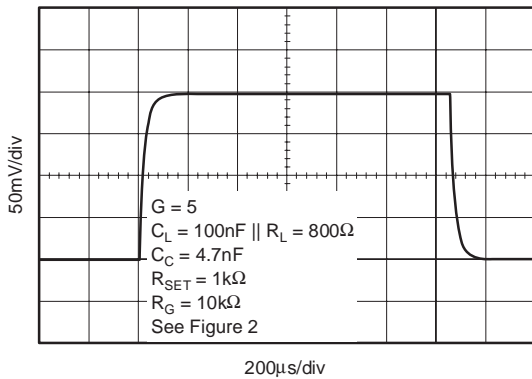

LARGE-SIGNAL STEP RESPONSE  
VOLTAGE MODE

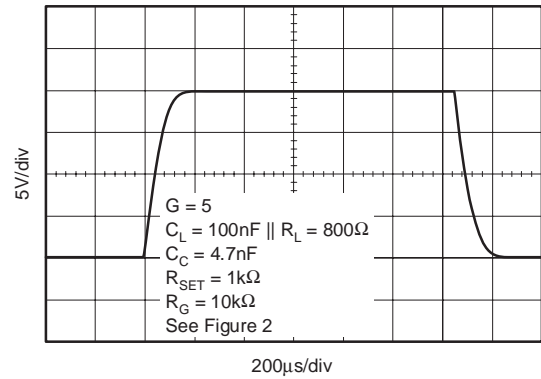

**TYPICAL CHARACTERISTICS (continued)**

At  $T_A = +25^\circ\text{C}$  and  $V_+ = \pm 20\text{V}$ , unless otherwise noted.

INPUT-REFERRED NOISE SPECTRUM  
VOLTAGE OUTPUT MODE

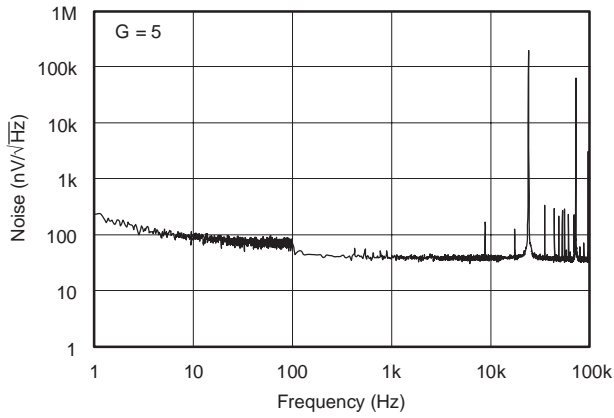

INPUT-REFERRED 0.1Hz to 10Hz NOISE  
VOLTAGE OUTPUT MODE

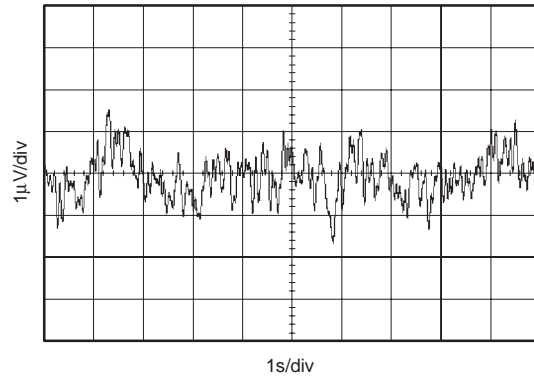

INPUT-REFERRED NOISE SPECTRUM  
CURRENT OUTPUT MODE

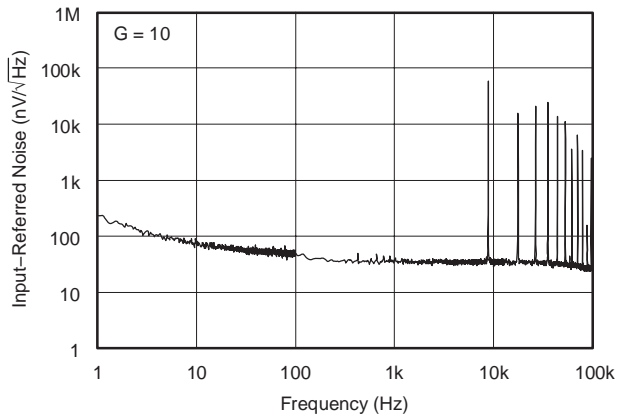

INPUT-REFERRED 0.1Hz to 10Hz NOISE  
CURRENT OUTPUT MODE

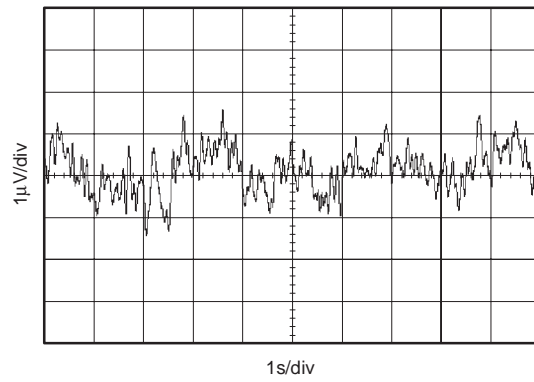

IA INPUT-REFERRED NOISE SPECTRUM

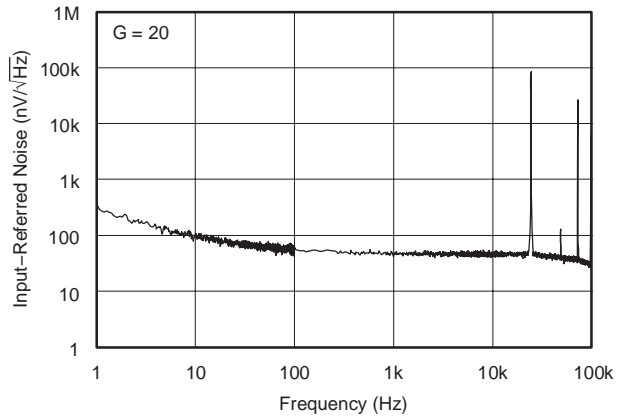

IA INPUT-REFERRED 0.1Hz to 10Hz NOISE

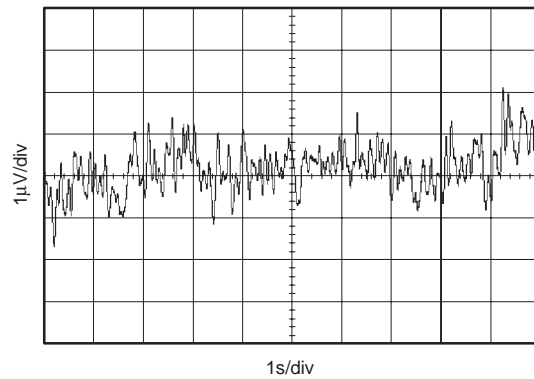

**TYPICAL CHARACTERISTICS (continued)**

At  $T_A = +25^\circ\text{C}$  and  $V_+ = \pm 20\text{V}$ , unless otherwise noted.

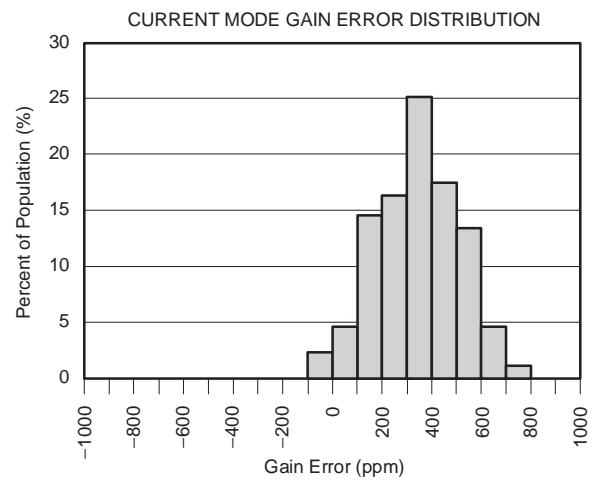
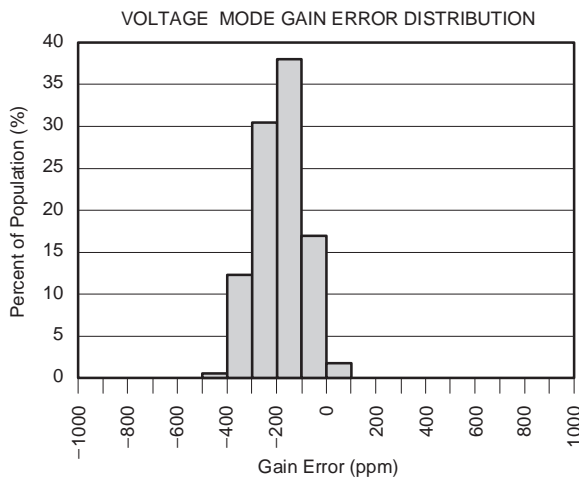
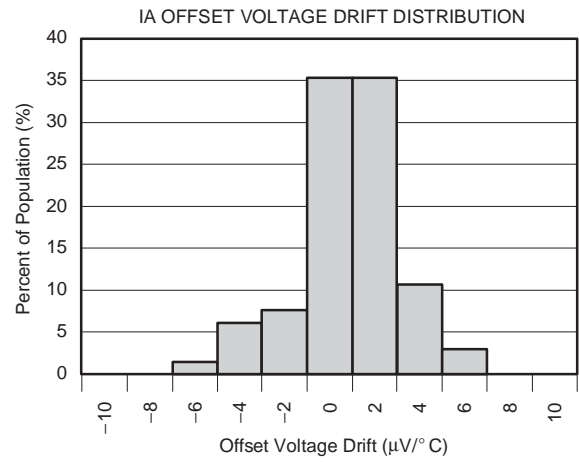
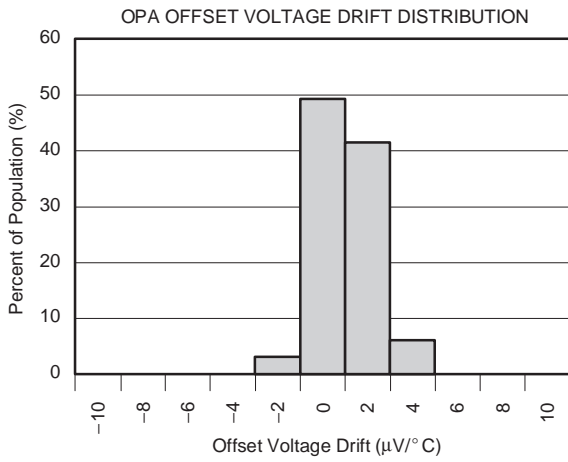
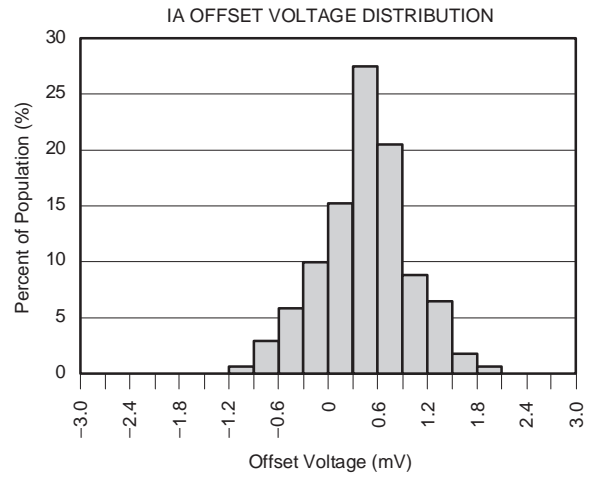
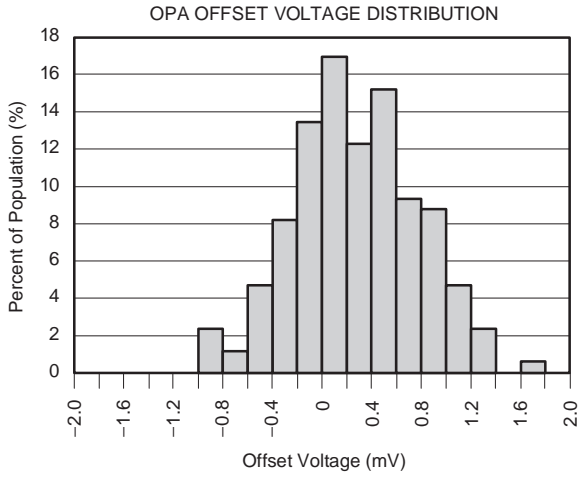

**TYPICAL CHARACTERISTICS (continued)**

At  $T_A = +25^\circ\text{C}$  and  $V_+ = \pm 20\text{V}$ , unless otherwise noted.

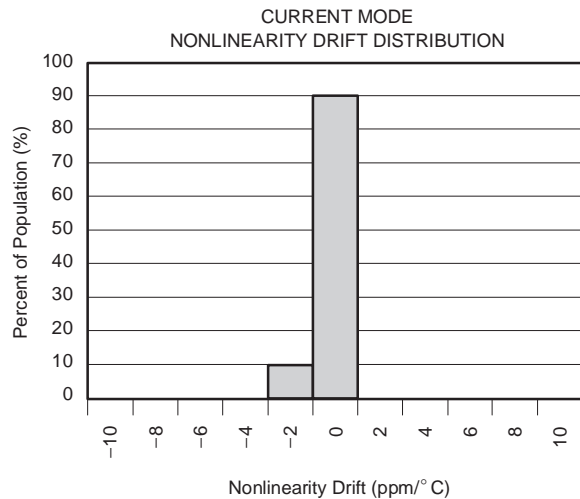
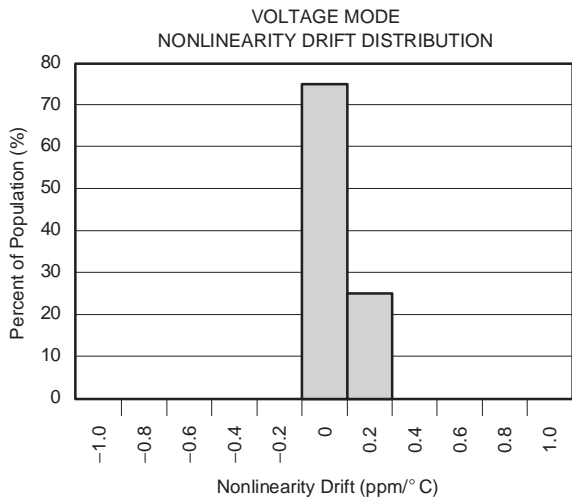
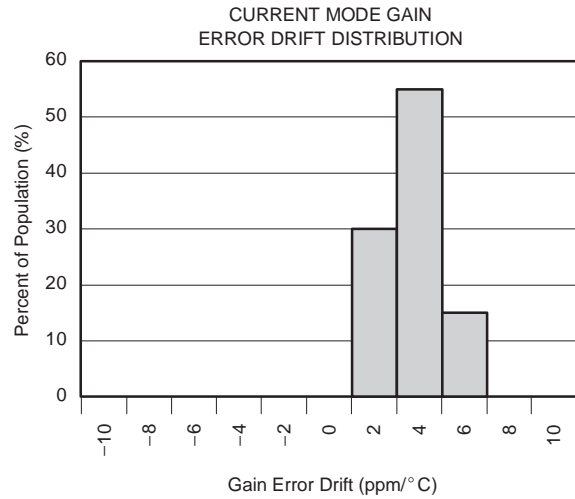
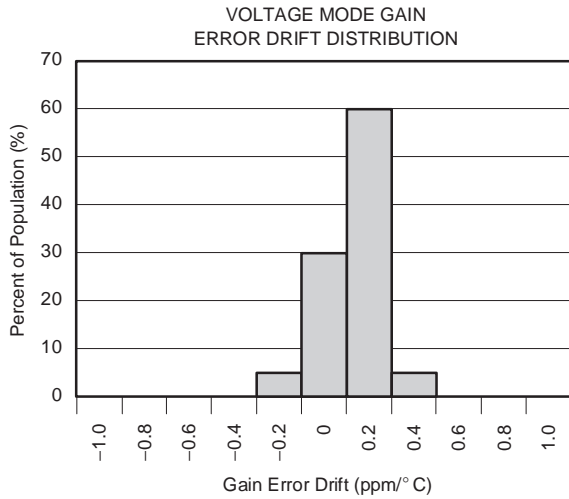
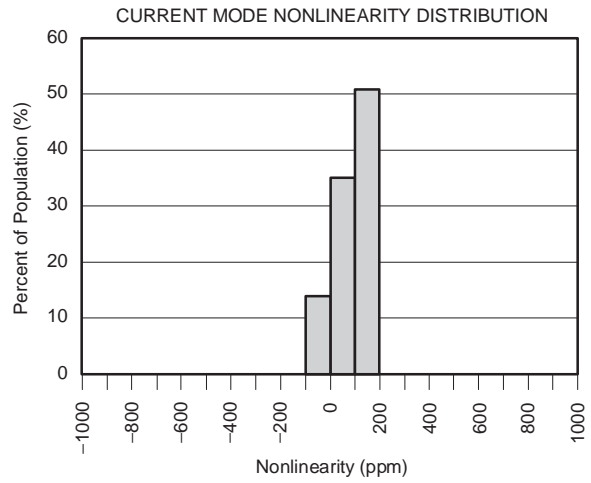
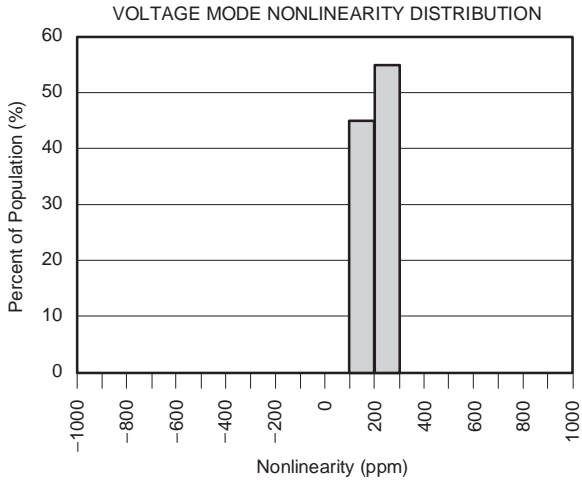

**TYPICAL CHARACTERISTICS (continued)**

At  $T_A = +25^\circ\text{C}$  and  $V_+ = \pm 20\text{V}$ , unless otherwise noted.

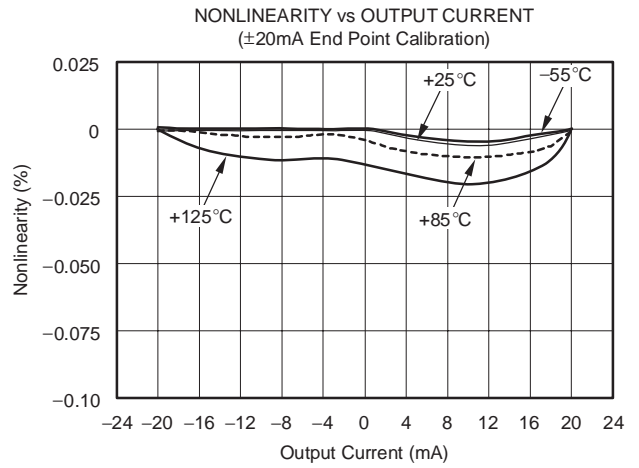
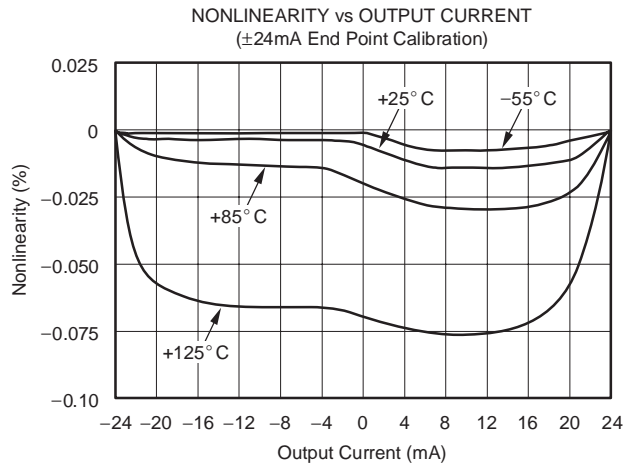
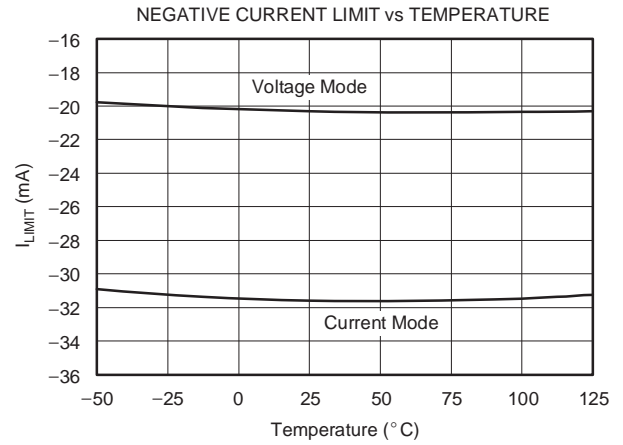
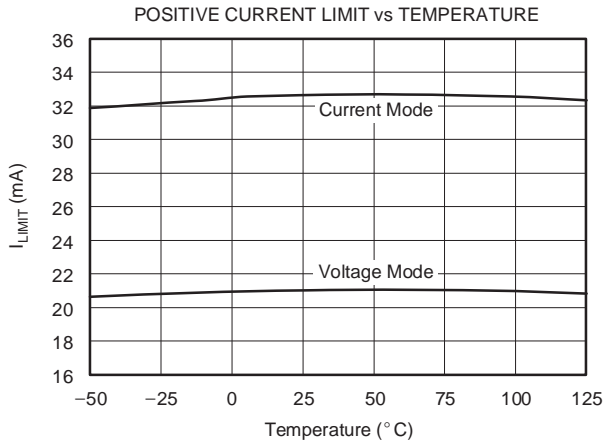

APPLICATION INFORMATION

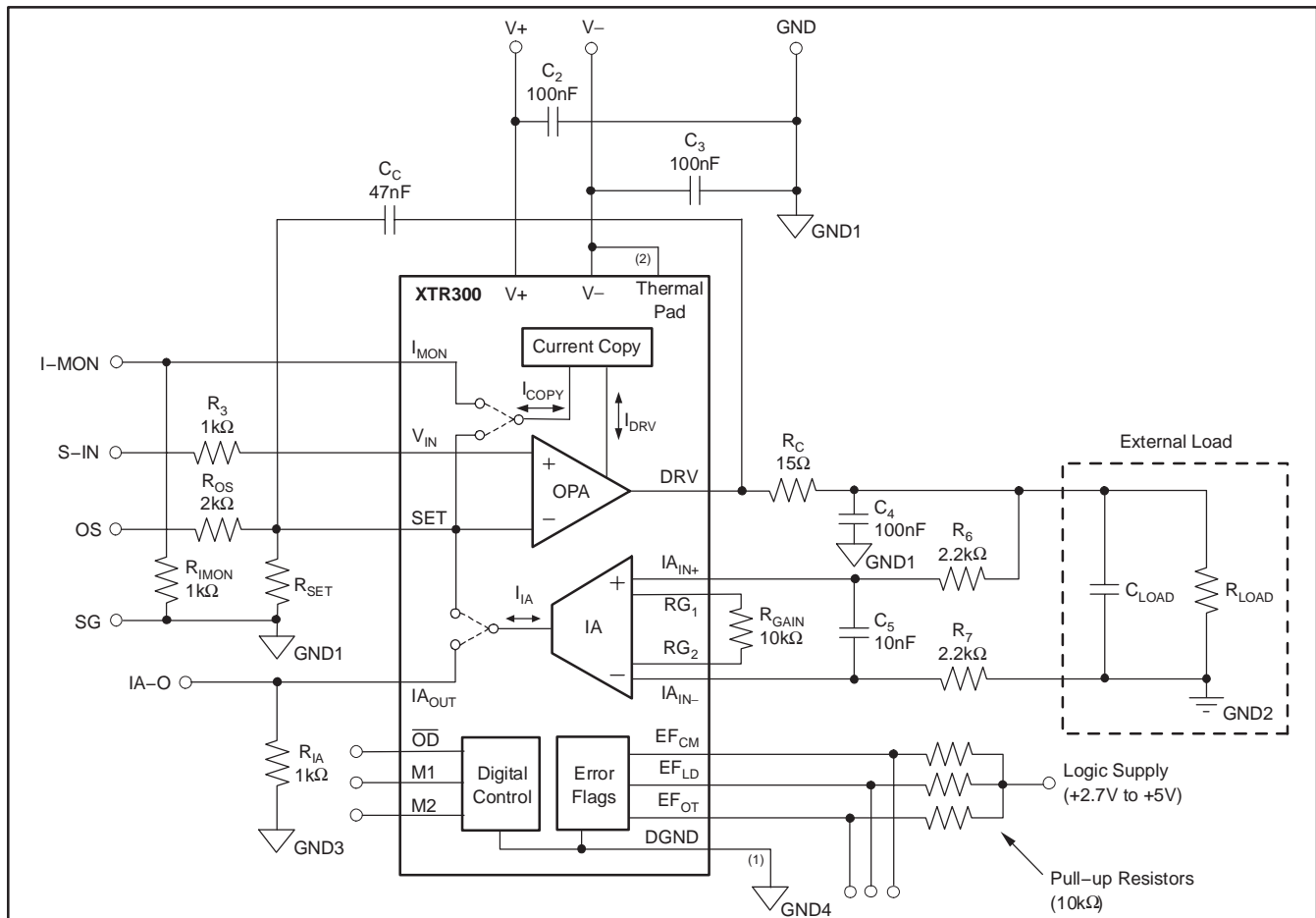

NOTE: (1) See the *Electrical Characteristics and Digital Input and Output* section for operating limits of DGND.  
 (2) Connect thermal pad to V-.

The following information should be considered during XTR300 circuit configuration:

- Recommended bypassing: 100nF or more for supply bypassing at each supply.
- R<sub>IMON</sub> can be in the kΩ-range or short-circuited if not used. Do not leave this current output unconnected—it would saturate the internal current source. The current at this I<sub>MON</sub> output is I<sub>DRV</sub>/10. Therefore, V<sub>IMON</sub> = R<sub>IMON</sub> (I<sub>DRV</sub>/10).
- R<sub>3</sub> is not required but can match R<sub>SET</sub> (or R<sub>SET</sub>||R<sub>OS</sub>) to compensate for the bias current.
- R<sub>IA</sub> can be short-circuited if not used. Do not leave this current output unconnected. R<sub>GAIN</sub> is selected to 10kΩ to match the output of 10V with 20mA for the equal input signal.
- R<sub>C</sub> ensures stability for unknown load conditions and limits the current into the internal protection diodes. C<sub>4</sub> helps protect the device. Over-voltage clamp diodes (standard 1N4002) might be necessary to protect the output.
- R<sub>6</sub>, R<sub>7</sub>, and C<sub>5</sub> protect the IA.
- R<sub>LOAD</sub> and C<sub>LOAD</sub> represent the load resistance and load capacitance.
- R<sub>SET</sub> defines the transfer gain. It can be split to allow a signal offset and, therefore, allow a 5V single-supply digital-to-analog converter (DAC) to control a ±10V or ±20mA output signal.

The XTR300 can be used with asymmetric supply voltages; however, the minimum negative supply voltage should be equal to or more negative than -3V (typically -5V). This supply value ensures proper control of 0V and 0mA with wire resistance, ground offsets, and noise added to the output. For positive output signals, the current requirement from this negative voltage source is less than 5mA.

GND1 through GND4 must be selected to fulfill specified operating ranges. DGND must be in the range of (V-) ≤ DGND ≤ (V+) -7V.

Figure 5. Standard Circuit Configuration

Built on a robust high-voltage BI-CMOS process, the XTR300 is designed to interface the 5V or 3V supply domain used for processors, signal converters, and amplifiers to the high-voltage and high-current industrial signal environment. It is specified for up to  $\pm 20V$  supply, but can also be powered asymmetrically (for example, +24V and -5V). It is designed to allow insertion of external circuit protection elements and drive large capacitive loads.

## FUNCTIONAL FEATURES

The XTR300 provides two basic functional blocks: an instrumentation amplifier (IA) and a driver that is a unique operational amplifier (OPA) for current or voltage output. This combination represents an analog output stage which can be digitally configured to provide either current or voltage output to the same terminal pin. Alternatively, it can be configured for independent measurement channels.

Three open collector error signals are provided to indicate output related errors such as over-current or open-load ( $EF_{LD}$ ) or exceeding the common-mode input range at the IA inputs ( $EF_{CM}$ ). An over-temperature flag ( $EF_{OT}$ ) can be used to control output disable to protect the circuit. The monitor outputs ( $I_{MON}$  and  $IA_{OUT}$ ) and the error flags offer optimal testability during operation and configuration. The  $I_{MON}$  output represents the current flowing into the load in voltage output mode, while the  $IA_{OUT}$  represents the voltage across the connectors in current output mode. Both monitor outputs can be connected together when used in current or voltage output mode because the monitor signals are multiplexed accordingly.

## VOLTAGE OUTPUT MODE

In voltage output mode (M1 and M2 are connected low or left unconnected), the feedback loop through the IA provides high impedance remote sensing of the voltage at the destination, compensating the resistance of a protection circuit, switches, wiring, and connector resistance. The output of the IA is a current that is proportional to the input voltage. This current is internally routed to the OPA summing junction through a multiplexer, as shown in Figure 6.

A 1:10 copy of the output current of the OPA can be monitored at the  $I_{MON}$  pin. This output current and the known output voltage can be used to calculate the load resistance or load power.

During an output short-circuit or an over-current condition the XTR300 output current is limited and  $EF_{LD}$  (load error, active low) flag is activated.

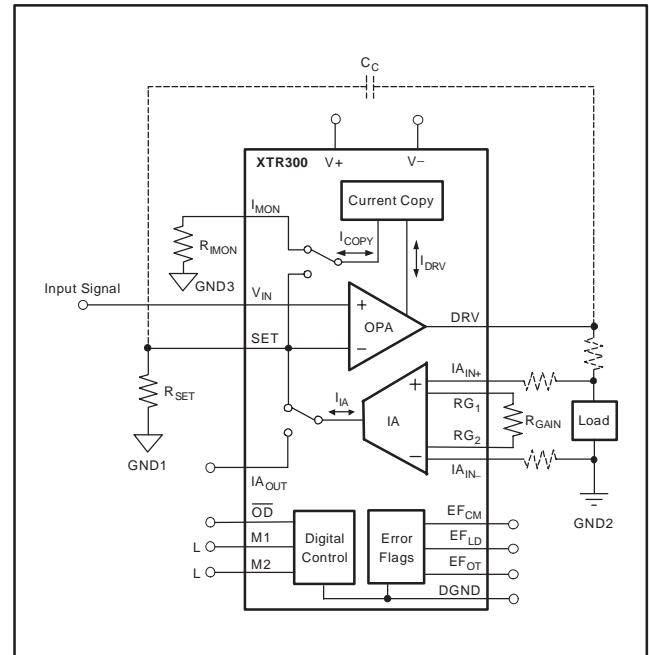

**Figure 6. Simplified Voltage Output Mode Configuration**

Applications not requiring the remote sense feature can use the OPA in stand-alone operation (M1 = high). In this case, the IA is available as a separate input channel.

The IA gain can be set by two resistors,  $R_{GAIN}$  and  $R_{SET}$ :

$$V_{OUT} = \frac{R_{GAIN}}{2R_{SET}} V_{IN} \quad (1)$$

or when adding an offset,  $V_{REF}$ , to get bidirectional output with a single-ended input:

$$V_{OUT} = \frac{R_{GAIN}}{2} \left( \frac{V_{IN}}{R_{SET}} + \frac{V_{IN} - V_{REF}}{R_{OS}} \right) \quad (2)$$

The  $R_{SET}$  resistor is also used in current output mode. Therefore, it is useful to define  $R_{SET}$  for the current mode, then set the ratio between current and voltage span with  $R_{GAIN}$ .

### CURRENT OUTPUT MODE

The XTR300 does not require a shunt resistor for current control because it uses a precise current mirror arrangement.

In current output mode (M1 connected low, or left unconnected and M2 connected high) a precise copy of 1/10th of the output is internally routed back to the summing junction of the OPA through a multiplexer, closing the control loop for the output current.

The OPA driver can deliver more than ±24mA within a wide output voltage range. An open-output condition or high-impedance load that prevents the flow of the required current activates the EF<sub>LD</sub> flag.

While in current output mode, a current (I<sub>IA</sub>) that is proportional to the voltage at the IA input is routed to IA<sub>OUT</sub> and can be used to monitor the load voltage. A resistor converts this current into voltage. This arrangement makes level shifting easy.

Alternatively, the IA can be used as an independent monitoring channel. If this output is not used, connect it to GND to maintain proper function of the monitor stage, as shown in Figure 7.

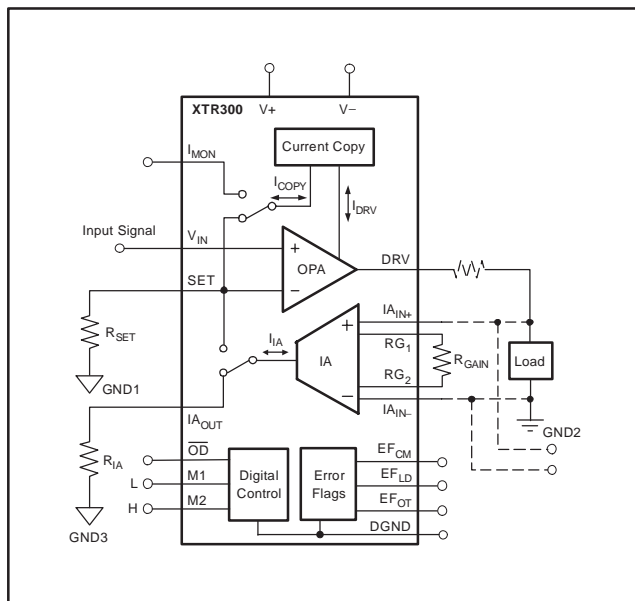

**Figure 7. Simplified Current Output Mode Configuration**

The transconductance (gain) can be set by the resistor, R<sub>SET</sub>, according to the equation:

$$I_{OUT} = \frac{10}{R_{SET}} V_{IN} \tag{3}$$

or when adding an offset V<sub>REF</sub> to get bidirectional output with a single-ended input:

$$I_{OUT} = 10 \left( \frac{V_{IN}}{R_{SET}} + \frac{V_{IN} - V_{REF}}{R_{OS}} \right) \tag{4}$$

### INPUT SIGNAL CONNECTION

It is possible to drive the XTR300 with a unidirectional input signal and still get a bidirectional output by adding an additional resistor, R<sub>OS</sub>, and an offset voltage signal, V<sub>REF</sub>. It can be a mid-point voltage or a signal to shift the output voltage to a desired value.

This design is illustrated in Figure 8a, Figure 8b, and Figure 8c. As with a normal operational amplifier, there are several options for offset-shift circuits. The input can be connected for inverting or noninverting gain. Unlike many op amp input circuits, however, this configuration uses current feedback, which removes the voltage relationship between the noninverting input and output potential because there is no feedback resistor.

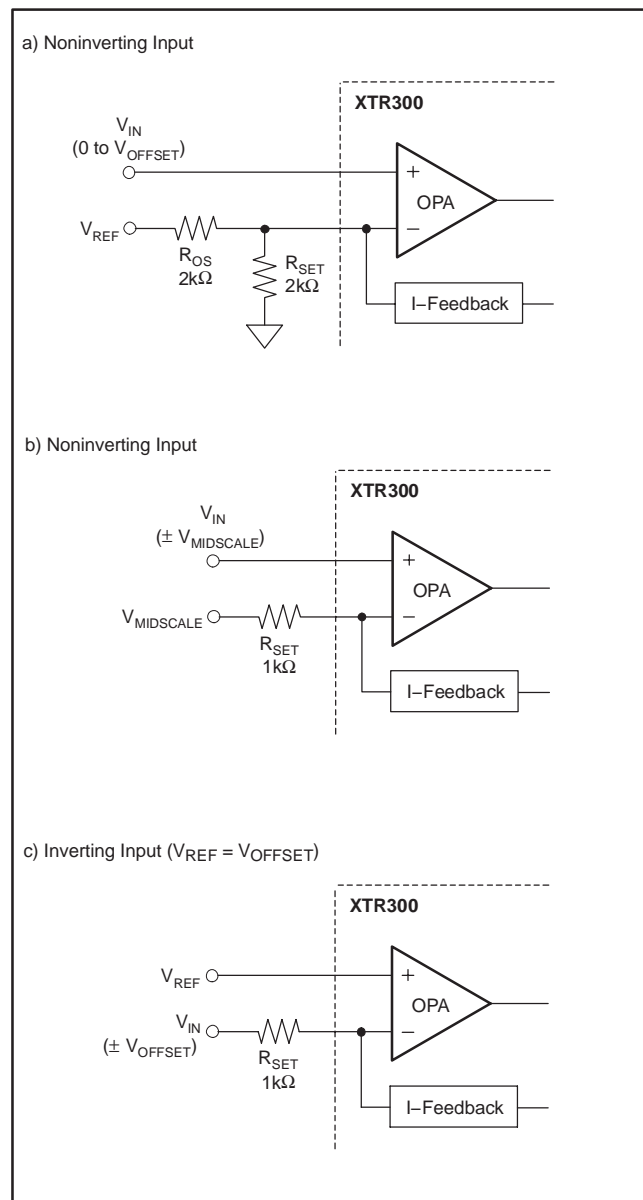

**Figure 8. Circuit Options for Op Amp Output Level-Shifting**



The input bias current effect on the offset voltage can be reduced by connecting a resistor in series with the positive input that matches the approximate resistance at the negative input. This resistor placed close to the input pin acts as a damping element and makes the design less sensitive to RF noise. See R<sub>3</sub> in Figure 5.

## EXTERNALLY-CONFIGURED MODE: OPA AND IA

It is possible to use the precision of the operational amplifier (OPA) and instrumentation amplifier (IA) independently from each other by configuring the digital control pins (M1 high). In this mode, the IA output current is routed to I<sub>AOUT</sub> and the copy of the OPA output current is routed to I<sub>MON</sub>, as shown in Figure 4.

This mode allows external configuration of the analog signal routing and feedback loop.

The current output IA has high input impedance, low offset voltage and drift, and very high common-mode rejection ratio. An external resistor (R<sub>IA</sub>) can be used to convert the output current of the IA (I<sub>IA</sub>) to an output voltage. The gain is given by:

$$I_{IA} = \frac{2}{R_{GAIN}} V_{IN} \text{ or } V_{IA} = \frac{2R_{IA}}{R_{GAIN}} V_{IN} \quad (5)$$

The OPA provides low drift and high voltage output swing that can be used like a common operational amplifier by connecting a feedback network around it. In this mode, the copy of the output current is available at the I<sub>MON</sub> pin (it includes the current into the feedback network). It provides an output current limit for protection, which can be set between two ranges by M2. The error flag indicates an over-current condition, as well as indicating driving the output into the supply rails.

Alternatively, the feedback can be closed through the I<sub>MON</sub> pin to create a precise voltage-to-current converter.

## DRIVER OUTPUT DISABLE

The OPA output (DRV) can be switched to a high-impedance mode by driving the  $\overline{OD}$  control pin low. This input can be connected to the over-temperature flag, EF<sub>OT</sub>, and a pull-up resistor to protect the IC from over-temperature by disconnecting the load.

The output disable mode can be used to sense and measure the voltage at the IA input pins without loading from the DRV output. This mode allows testing of any voltage present at the I/O connector. However, consider the bias current of the IA input pins.

The digital control inputs, M1 and M2, set the four operation modes of the XTR300 as shown in Table 1. When M1 is asserted low, M2 determines voltage or current mode and the corresponding appropriate current limit (I<sub>SC</sub>) set-

ting. When M1 is high, the internal feedback connections are opened; I<sub>AOUT</sub> and I<sub>MON</sub> are both connected to the output pins; and M2 only determines the current limit (I<sub>SC</sub>) setting.

## SUMMARY OF CONFIGURATION MODES<sup>(1)</sup>

M1	M2	MODE	DESCRIPTION
L	L	V <sub>OUT</sub>	Voltage Output Mode, I <sub>SC</sub> = 20mA
L	H	I <sub>OUT</sub>	Current Output Mode, I <sub>SC</sub> = 32mA
H	L	Ext	IA and I <sub>MON</sub> on ext. pins, I <sub>SC</sub> = 20mA
H	H	Ext	IA and I <sub>MON</sub> on ext. pins, I <sub>SC</sub> = 32mA

(1)  $\overline{OD}$  is a control pin independent of M1 or M2. See the *Driver Output Disable* section.

**Table 1. Mode Configuration**

M1 and M2 are pulled low internally with 1μA. Terminate these two pins to avoid noise coupling.

Output disable ( $\overline{OD}$ ) is internally pulled high with approximately 1μA.

## DRIVING CAPACITIVE LOADS AND LOOP COMPENSATION

For normal operation, the driver OPA and the IA are connected in a closed loop for voltage output. In current output mode, the current copy closes the loop directly.

In current output mode, loop compensation is not critical, even for large capacitive loads. However, in voltage output mode, the capacitive load, together with the source impedance and the impedance of the protection circuit, generates additional phase lag. The IA input might also be protected by a low-pass filter that influences phase in the closed loop.

The loop compensation low-pass filter consists of C<sub>C</sub> and the parallel resistance of R<sub>OS</sub> and R<sub>SET</sub>. For loop stability with large capacitive load, the external phase shift has to be added to the OPA phase. With C<sub>C</sub>, the voltage gain of the OPA has to approach zero at the frequency where the total phase approaches 180° + 135°.

The best stability for large capacitive loads is provided by adding a small resistor, R<sub>C</sub> (15Ω). See the *Output Protection* section.

An empirical method of evaluation is using a square wave input signal and observing the settling after transients. Use small signal amplitudes only—steep signal edges cause excessive current to flow into the capacitive load and may activate the current limit, which hides or prevents oscillation. A small-signal oscillation can be hidden from large capacitive loads, but observing the I<sub>MON</sub> output on an appropriate resistor (use a similar value like R<sub>SET</sub>||R<sub>OS</sub>) would indicate stability issues. Note that noise pulses at I<sub>MON</sub> dur-

ing overload ( $EF_{LD}$  active) are normal and are caused by cycling of the current mirror.

The voltage output mode includes the IA in the loop. An additional low-pass filter in the input reverses the phase and therefore increases the signal bandwidth of the loop, but also increases the delay. Again, loop stability has to be observed. Overloading the IA disconnects the closed loop and the output voltage rails.

### INTERNAL CURRENT SOURCES, SWITCHING NOISE, AND SETTLING TIME

The accuracy of the current output mode and the DC performance of the IA rely on dynamically-matched current mirrors.

Identical current sources are rotated to average out mismatch errors. It can take several clock cycles of the internal 100kHz oscillator (or a submultiple of that frequency) to reach full accuracy. This may dominate the settling time to the 0.1% accuracy level and can be as much as 100 $\mu$ s in current output mode or 40 $\mu$ s in voltage output mode.

A small portion of the switching glitches appear at the DRV output, and also at the  $I_{MON}$  and  $IA_{MON}$  outputs. The standard circuit configuration, with  $R_C$ ,  $C_4$ , and  $C_C$ , which are required for loop compensation and output protection, also helps reduce the noise to negligible levels at the signal output. If necessary, the monitor outputs can be filtered with a shunt capacitor.

### IA STRUCTURE, VOLTAGE MONITOR

The instrumentation amplifier has high-impedance NPN transistor inputs that do not load the output signal, which is especially important in current output mode. The output signal is a controlled current that is multiplexed either to the SET pin (to close the voltage output loop) or to  $IA_{OUT}$  (for external access).

The principal circuit is shown in Figure 9. The two input buffer amplifiers reproduce the input difference voltage across  $R_{GAIN}$ . The resulting current through this resistor is bidirectionally mirrored to the output. That mirroring results in the ideal transfer function of:

$$I_{IA} = IA_{OUT} = 2 (IA_{IN+} - IA_{IN-}) / R_{GAIN} \quad (6)$$

The accuracy and drift of  $R_{GAIN}$  defines the accuracy of the voltage to current conversion. The high accuracy and stability of the current mirrors result from a cycling chopper technique.

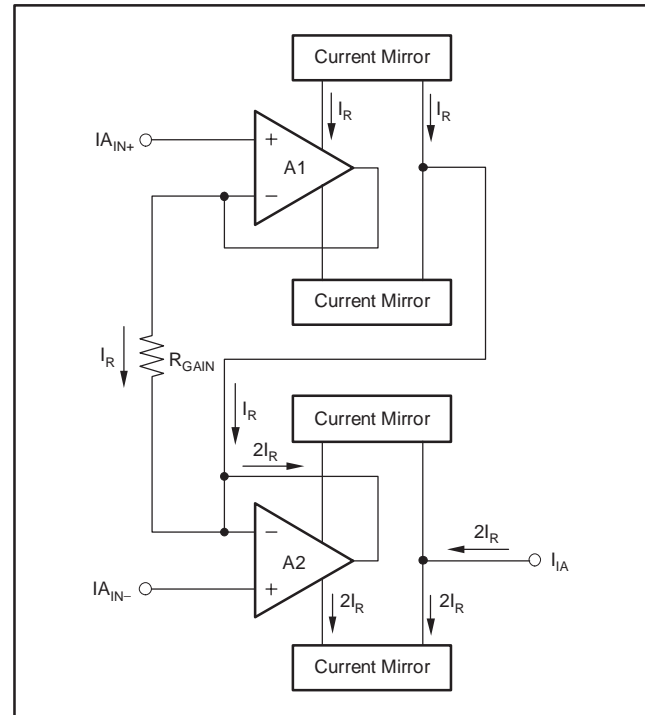

Figure 9. IA Block Diagram

The output current,  $IA_{OUT}$ , of the instrumentation amplifier is limited to protect the internal circuitry. This current limit has two settings controlled by the state of M2 (see Electrical Characteristics, Short-Circuit Current specification). Note that if  $R_{SET}$  is too small, the current output limitation of the instrumentation amplifier can disrupt the closed loop of the XTR300 in voltage output mode. With  $M2 = low$ , the nominal  $R_{GAIN}$  of 10k $\Omega$  allows an input voltage of 20V $_{PP}$ , which produces an output current of 4mA $_{PP}$ . When using lower resistors for  $R_{GAIN}$  that can allow higher currents, the IA output current limitation must be taken into account.

### CURRENT MONITOR

In current output mode ( $M2 = high$ ), the XTR300 provides high output impedance. A precision current mirror generates an exact 1/10th copy of the output current and this current is either routed to the summing junction of the OPA to close the feedback loop (in the current output mode) or to the  $I_{MON}$  pin for output current monitoring in other operating modes.

The high accuracy and stability of this current split results from a cycling chopper technique. This design eliminates the need for a precise shunt resistor or a precise shunt-voltage measurement, which would require high common-mode rejection performance.

During a saturation condition of the DRV output (the error flag is active), the monitor output ( $I_{MON}$ ) shows a current peak because the loop opens. Glitches from the current mirror chopper appear during this time in the monitor signal. This part of the signal cannot be used for measurement.

## ERROR FLAGS

The XTR300 is designed for testability of its proper function and allows observation of the conditions at the load connection without disrupting service.

If the output signal is not in accordance to the transfer function, an error flag is activated (limited by the dynamic response capabilities). These error flags are in addition to the monitor outputs,  $I_{MON}$  and  $IA_{OUT}$ , which allow the momentary output current (in voltage mode) or output voltage (in current mode) to be read back.

This combination of error flag and monitor signal allows easy observation of the XTR300 for function and working condition, providing the basis for not only remote control, but also for remote diagnosis.

All error flags of the XTR300 have open collector outputs with a weak pull-up of approximately  $1\mu\text{A}$  to an internal 5V. External pull-up resistors to the logic voltage are required when driving 3V or 5V logic.

The output sink current should not exceed 5mA. This is just enough to directly drive optical-couplers, but a current-limiting resistor is required.

There are three error flags:

- **IA Common-Mode Over-Range ( $EF_{CM}$ )**—goes low as soon as the inputs of the IA reach the limits of the linear operation for the input voltage.  
This flag shows noise from the saturated current mirrors which can be filtered with a capacitor to GND.
- **Load Error ( $EF_{LD}$ )**—indicates fault conditions driving voltage or current into the load. In voltage output mode it monitors the voltage limits of the output swing and the current limit condition caused from short or low load resistance. In current output mode it indicates a saturation into the supply rails from a high load resistance or open load.
- **Over-Temperature Flag ( $EF_{OT}$ )**—is a digital output that goes low if the chip temperature reaches a temperature of  $+140^\circ\text{C}$  and resets as soon as it cools down to  $+125^\circ\text{C}$ . It does not automatically shut down the output; it allows the user system to take action on the situation. If desired, this output can be connected to output disable ( $\overline{OD}$ ) which disables the output and

therefore removes the source of power. This connection acts like an automatic shut down, but requires an external pull-up resistor to safely override the internal current sources. The IA channel is not affected, which allows continuous observation of the voltage at the output.

## DIGITAL COMMUNICATION: HART

The bandwidth and drive capability of the XTR300 are sufficient to transmit communication signals such as HART. The combination of current monitor and voltage sense with the IA circuit enables communication signal transmission from the signal output connector to the monitor pins in both current or voltage output mode. In current output mode, the signal arrives at  $IA_{OUT}$ ; in voltage output mode the communication signal modulates the DRV current and arrives at  $I_{MON}$ . Both  $IA_{OUT}$  and  $I_{MON}$  can be connected together because they are internally multiplexed according to the output mode (while  $M1 = \text{low}$ ).

Driving a communication signal through the output connector back into the system or sensor, regardless of the output mode, enables easy configuration, calibration, diagnosis, and universal communication.

## DIGITAL I/O AND GROUND CONSIDERATIONS

The XTR300 offers voltage output mode, current output mode, external configuration, and instrumentation mode (voltage input). In addition, the internal feedback mode can be disconnected and external loop connections can be made. These modes are controlled by  $M1$  and  $M2$  (see the function table). The  $\overline{OD}$  input pin controls enable or disable of the output stage ( $\overline{OD}$  is active low).

The digital I/O is referenced to DGND and signals on this pin should remain within 5V of the DGND potential. This DGND pin carries the output low-current (sink current) of the logic outputs. DGND can be connected to a potential within the supply voltage but needs to be 8V below the positive supply. Proper connection avoids current from the digital outputs flowing into the analog ground.

It is important to note that DGND has normally reverse-biased diodes connected to the supply. Therefore, high and destructive currents could flow if DGND is driven beyond the supply rails by more than a diode forward voltage. *Avoid this condition during power-on and power-off!*

## OUTPUT PROTECTION

The XTR300 is intended to operate in a harsh industrial environment. Therefore, a robust semiconductor process was chosen for this design. However, some external protection is still required.

The instrumentation amplifier inputs can be protected by external resistors that limit current into the protection cell behind the IC-pins, as shown in Figure 10. This cell conducts to the power-supply connection through a diode as soon as the input voltage exceeds the supply voltage. The circuit configuration example shows how to arrange these two external resistors.

The bias current is best cancelled if both resistors are equal. The additional capacitor reduces RF noise in the input signal to the IA.

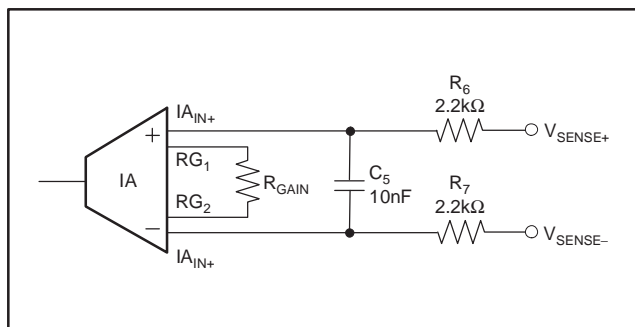
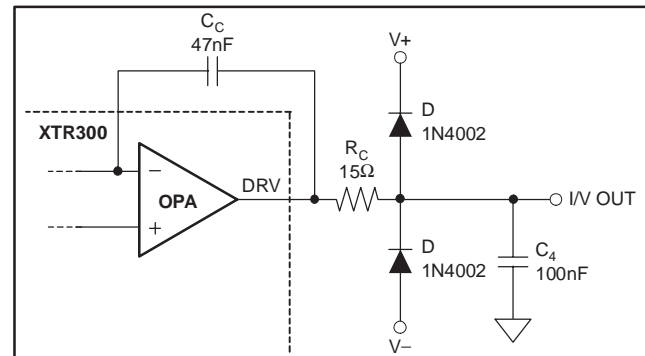

**Figure 10. Current Limiting Resistors**

The load connection to the DRV output must be low impedance; therefore, external protection diodes may be necessary to handle excessive currents, as shown in Figure 11. The internal protection diodes start to conduct earlier than a normal external PN-type diode because they are affected by the higher die temperature. Therefore, either Schottky diodes are required, or an additional resistor ( $R_C$ ) can be placed in series with the input. An example of this protection is shown in Figure 11. Assuming the standard diodes limit the voltage to 1.4V and the internal diodes clamp at 0.7V, this resistor can limit the current into the internal protection diodes to 50mA:

$$(1.4V - 0.7V)/15\Omega = 47mA \quad (7)$$

$R_C$  is also part of the recommended loop compensation.  $C_4$  helps protect the output against RFI and high-voltage spikes.



**Figure 11. Example for DRV Output Protection**

## POWER ON/OFF GLITCH

When power is turned on or off, most analog amplifiers generate some glitching of the output because of internal circuit thresholds and capacitive charges. Characteristics of the supply voltage, as well as its rise and fall time, also directly influence output glitches. Load resistance and capacitive load affect the amplitude as well.

The output disable control ( $\overline{OD}$ ) allows good control over the output during power-on, power-off, and system down time by providing a high impedance to the output. Figure 12a, Figure 12b, and Figure 12c show the output voltage with the output disabled during power on and off—no glitch can be seen on the output signal. Holding  $\overline{OD}$  low also prevents glitches in current output mode. Figure 12c indicates no glitches when transitioning from disable to enable.

All measurements are made with a load resistance of 1k $\Omega$  and tested in the circuit configuration of Figure 5.  $\overline{OD}$  has an internal pull-up of approximately 1 $\mu$ A; therefore, a 100k $\Omega$  resistor provides safe pull-down during power on—make sure the logic controlling the  $\overline{OD}$  pin does not glitch.

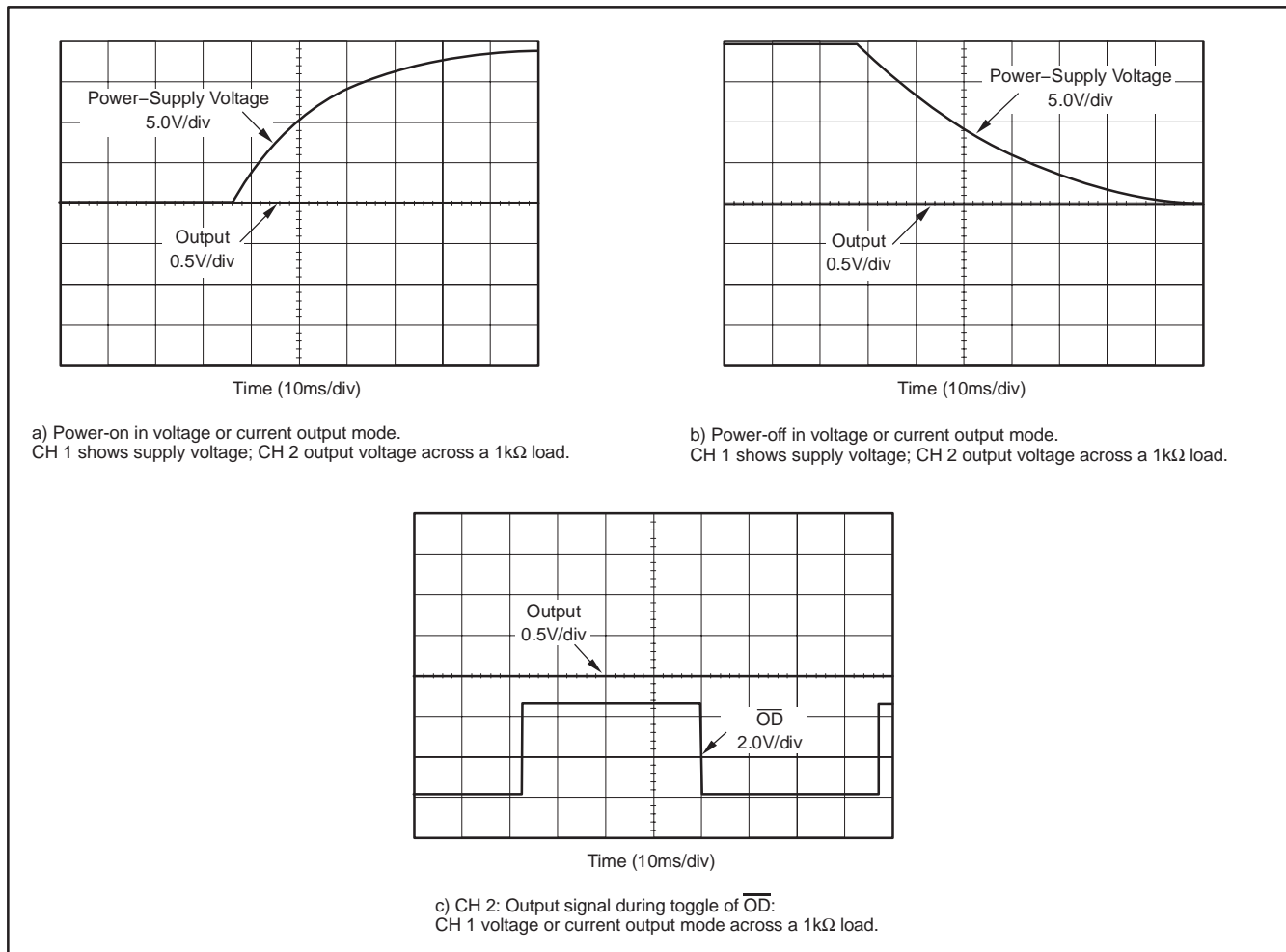
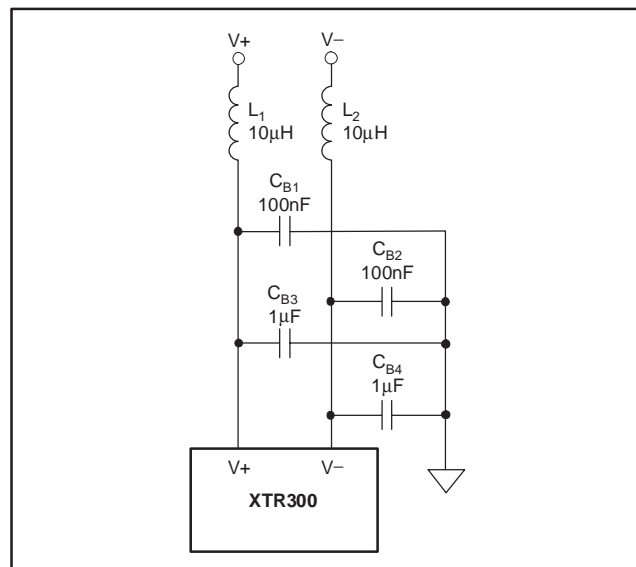

**Figure 12. Output Signal with Output Disabled During Power On/Off**

### LAYOUT CONSIDERATIONS

Supply bypass capacitors should be close to the package and connected with low-impedance conductors. Avoid noise coupled into  $R_{GAIN}$ , and observe wiring resistance. For thermal management, see the *Heat Sinking* section.

Layout for the XTR300 is not critical; however, its internal current chopping works best with good (low dynamic impedance) supply decoupling. Therefore, avoid through-hole contacts in the connection to the bypass capacitors or use multiple through-hole contacts. Switching noise from chopper-type power supplies should be filtered enough to reduce influence on the circuit. Small resistors ( $2\Omega$ , for example) or damping inductors in series with the supply connection (between the DC/DC converter and the XTR circuit) act as a decoupling filter together with the bypass capacitor, as shown in Figure 13.



**Figure 13. Suggested Supply Decoupling for Noisy Chopper-Type Supplies**



Resistors connected close to the input pins help dampen environmental noise coupled into conductor traces. Therefore, place the OPA input- and IA input-related resistors close to the package. Also, avoid additional wire resistance in series to  $R_{SET}$ ,  $R_{OS}$ , and  $R_{GAIN}$  (observe the reliability of the through-hole contacts), because this could produce gain and offset error as well as drift;  $1\Omega$  is already 0.1% of the  $1k\Omega$  resistor.

The exposed lead-frame die pad on the bottom of the package must be connected to  $V_-$ , pin 11 (see the *QFN Package* section for more details).

## QFN PACKAGE

The XTR300 is available in a QFN package. This leadless, near chip-scale package maximizes board space and enhances thermal and electrical characteristics through an exposed pad.

QFN packages are physically small, have a smaller routing area, and improved thermal performance. For optimal heat performance, the exposed power pad must be connected to an adequate heat slug with at least six thermal vias to a copper area. See the example land pattern RGW (S-PQFP-N20), available for download at [www.ti.com](http://www.ti.com) or at the end of this datasheet.

The QFN package can be easily mounted using standard printed circuit board (PCB) assembly techniques. See Application Note, *QFN/SON PCB Attachment* (SLUA271) and Application Report, *Quad Flatpack No-Lead Logic Packages* (SCBA017), available for download at [www.ti.com](http://www.ti.com), for more information.

The exposed leadframe die pad on the bottom of the package must be connected to the  $V_-$  pin, and proper heat sinking has to be provided.

## HEAT SINKING

Power dissipation depends on power supply, signal, and load conditions. It is dominated by the power dissipation of the output transistors of the OPA. For DC signals, power dissipation is equal to the product of output current,  $I_{OUT}$  and the output voltage across the conducting output transistor ( $V_S - V_{OUT}$ ).

It is important to note that the temperature protection will not shut the part down in over-temperature conditions, unless the  $EF_{OT}$  pin is connected to the output enable pin  $\overline{OD}$ ; see the section on *Driver Output Disable*.

The power that can be safely dissipated by the package is related to the ambient temperature and the heatsink design.

The QFN package was specifically designed to provide excellent power dissipation, but board layout greatly influences the heat dissipation of the package. Refer to the *QFN Package* section for further details.

The XTR300 has a junction-to-ambient thermal resistance ( $\theta_{JA}$ ) value of  $38^\circ\text{C}/\text{W}$  when soldered to a 2-oz copper plane. This value can be further decreased by the addition of forced air. See Table 2 for the junction-to-ambient thermal resistance of the QFN-20 package. Junction temperature should be kept below  $+125^\circ\text{C}$  for reliable operation. The junction temperature can be calculated by:

$$T_J = T_A + P_D \cdot \theta_{JA}$$

$$\text{where } \theta_{JA} = \theta_{JC} + \theta_{CA}$$

$$T_J = \text{Junction Temperature } (^\circ\text{C})$$

$$T_A = \text{Ambient Temperature } (^\circ\text{C})$$

$$P_D = \text{Power Dissipated (W)}$$

$$\theta_{JA} = \text{Junction-to-Ambient Thermal Resistance}$$

$$\theta_{JC} = \text{Junction-to-Case Thermal Resistance}$$

$$\theta_{CA} = \text{Case-to-Air Thermal Resistance}$$

HEATSINKING METHOD	$\theta_{JA}$
The part is soldered to a 2-oz copper pad under the exposed pad.	38
Soldered to copper pad with forced airflow (150lfm).	36
Soldered to copper pad with forced airflow (250lfm).	35
Soldered to copper pad with forced airflow (500lfm).	34

**Table 2. Junction-to-Ambient Thermal Resistance with Various Heatsinking Efforts**

To appropriately determine the required heatsink area, required power dissipation should be calculated and the relationship between power dissipation and thermal resistance should be considered to minimize overheat conditions and allow for reliable long-term operation.

The efficiency of the heat sinking can be tested using the  $EF_{OT}$  output signal. This output goes low at nominally  $+140^\circ\text{C}$  junction temperature (assume 6% tolerance). With full-power dissipation—for example, maximum current into a  $0\Omega$  load—the ambient temperature can be slowly raised until the OT flag goes low; at this point, the usable operation condition is determined.

The recommended landing pattern is shown in document RGW (S-PQFP-N20). The nine (not less than six) through-hole contacts of the inner heat sink solder pad connect to a copper plane in any one layer. It must be large enough to efficiently distribute the heat into the PCB. This pad has to be electrically connected to the  $V_-$  pin to provide the required substrate connection.

**PACKAGING INFORMATION**

Orderable Device	Status <sup>(1)</sup>	Package Type	Package Drawing	Pins	Package Qty	Eco Plan <sup>(2)</sup>	Lead/Ball Finish	MSL Peak Temp <sup>(3)</sup>
XTR300AIRGWR	ACTIVE	QFN	RGW	20	3000	Green (RoHS & no Sb/Br)	CU NIPDAU	Level-2-260C-1 YEAR
XTR300AIRGWRG4	ACTIVE	QFN	RGW	20	3000	Green (RoHS & no Sb/Br)	CU NIPDAU	Level-2-260C-1 YEAR
XTR300AIRGWT	ACTIVE	QFN	RGW	20	250	Green (RoHS & no Sb/Br)	CU NIPDAU	Level-2-260C-1 YEAR
XTR300AIRGWTG4	ACTIVE	QFN	RGW	20	250	Green (RoHS & no Sb/Br)	CU NIPDAU	Level-2-260C-1 YEAR

<sup>(1)</sup> The marketing status values are defined as follows:

**ACTIVE:** Product device recommended for new designs.

**LIFEBUY:** TI has announced that the device will be discontinued, and a lifetime-buy period is in effect.

**NRND:** Not recommended for new designs. Device is in production to support existing customers, but TI does not recommend using this part in a new design.

**PREVIEW:** Device has been announced but is not in production. Samples may or may not be available.

**OBSOLETE:** TI has discontinued the production of the device.

<sup>(2)</sup> Eco Plan - The planned eco-friendly classification: Pb-Free (RoHS), Pb-Free (RoHS Exempt), or Green (RoHS & no Sb/Br) - please check <http://www.ti.com/productcontent> for the latest availability information and additional product content details.

**TBD:** The Pb-Free/Green conversion plan has not been defined.

**Pb-Free (RoHS):** TI's terms "Lead-Free" or "Pb-Free" mean semiconductor products that are compatible with the current RoHS requirements for all 6 substances, including the requirement that lead not exceed 0.1% by weight in homogeneous materials. Where designed to be soldered at high temperatures, TI Pb-Free products are suitable for use in specified lead-free processes.

**Pb-Free (RoHS Exempt):** This component has a RoHS exemption for either 1) lead-based flip-chip solder bumps used between the die and package, or 2) lead-based die adhesive used between the die and leadframe. The component is otherwise considered Pb-Free (RoHS compatible) as defined above.

**Green (RoHS & no Sb/Br):** TI defines "Green" to mean Pb-Free (RoHS compatible), and free of Bromine (Br) and Antimony (Sb) based flame retardants (Br or Sb do not exceed 0.1% by weight in homogeneous material)

<sup>(3)</sup> MSL, Peak Temp. -- The Moisture Sensitivity Level rating according to the JEDEC industry standard classifications, and peak solder temperature.

**Important Information and Disclaimer:**The information provided on this page represents TI's knowledge and belief as of the date that it is provided. TI bases its knowledge and belief on information provided by third parties, and makes no representation or warranty as to the accuracy of such information. Efforts are underway to better integrate information from third parties. TI has taken and continues to take reasonable steps to provide representative and accurate information but may not have conducted destructive testing or chemical analysis on incoming materials and chemicals. TI and TI suppliers consider certain information to be proprietary, and thus CAS numbers and other limited information may not be available for release.

In no event shall TI's liability arising out of such information exceed the total purchase price of the TI part(s) at issue in this document sold by TI to Customer on an annual basis.

**TAPE AND REEL INFORMATION**



**QUADRANT ASSIGNMENTS FOR PIN 1 ORIENTATION IN TAPE**



\*All dimensions are nominal

Device	Package Type	Package Drawing	Pins	SPQ	Reel Diameter (mm)	Reel Width W1 (mm)	A0 (mm)	B0 (mm)	K0 (mm)	P1 (mm)	W (mm)	Pin1 Quadrant
XTR300AIRGWR	QFN	RGW	20	3000	330.0	12.4	5.3	5.3	1.5	8.0	12.0	Q2
XTR300AIRGWT	QFN	RGW	20	250	180.0	12.4	5.3	5.3	1.5	8.0	12.0	Q2



**TAPE AND REEL BOX DIMENSIONS**



\*All dimensions are nominal

Device	Package Type	Package Drawing	Pins	SPQ	Length (mm)	Width (mm)	Height (mm)
XTR300AIRGWR	QFN	RGW	20	3000	346.0	346.0	29.0
XTR300AIRGWT	QFN	RGW	20	250	190.5	212.7	31.8

RGW (S-PQFP-N20)

PLASTIC QUAD FLATPACK

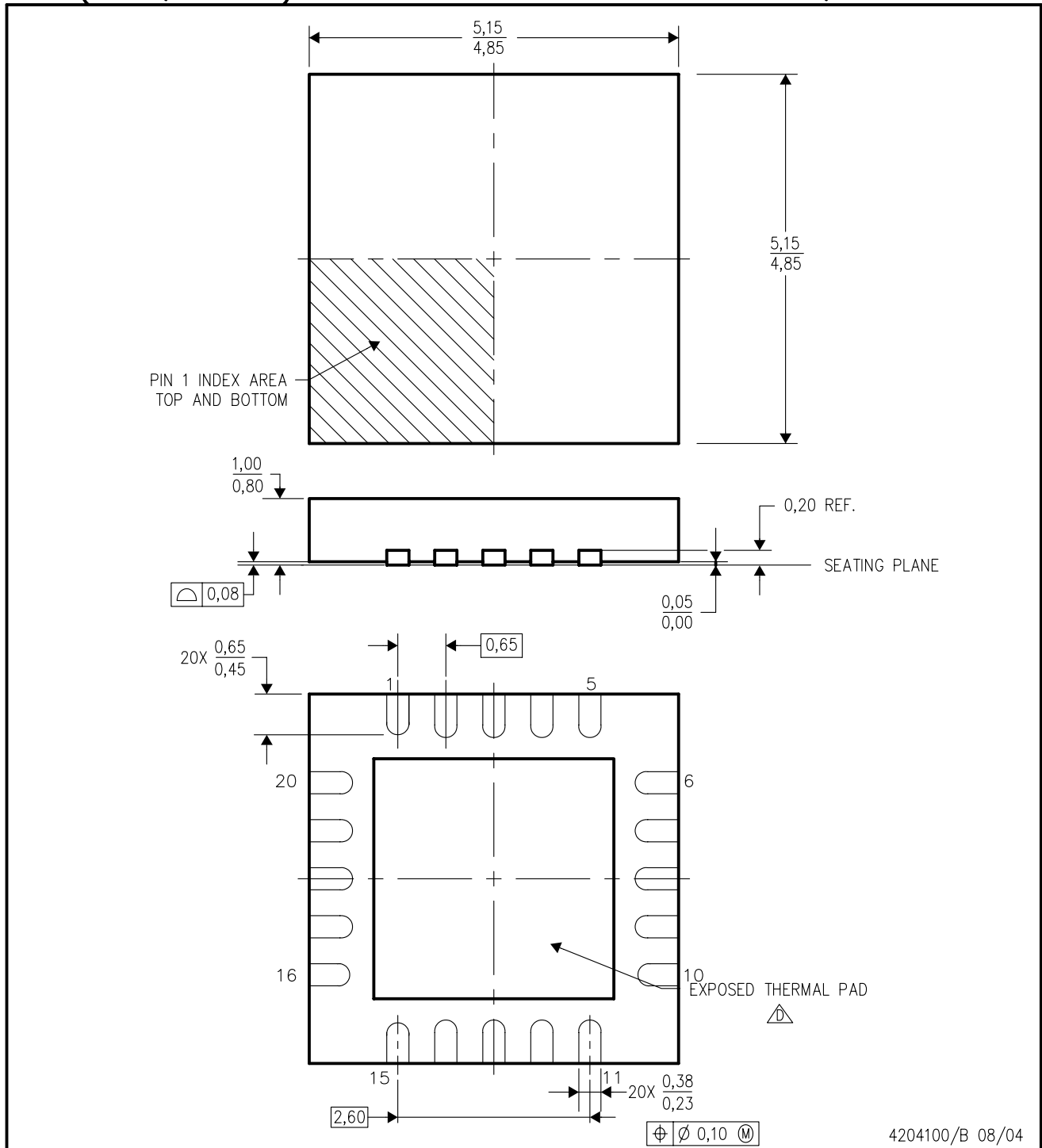

4204100/B 08/04

- NOTES:
- A. All linear dimensions are in millimeters. Dimensioning and tolerancing per ASME Y14.5-1994.
  - B. This drawing is subject to change without notice.
  - C. Quad Flat pack, No-leads (QFN) package configuration
  - △ The package thermal pad must be soldered to the board for thermal and mechanical performance.. See the Product Data Sheet for details regarding the exposed thermal pad dimensions.
  - E. Falls within JEDEC MO-220.

THERMAL INFORMATION

This package incorporates an exposed thermal pad that is designed to be attached directly to an external heatsink. The thermal pad must be soldered directly to the printed circuit board (PCB). After soldering, the PCB can be used as a heatsink. In addition, through the use of thermal vias, the thermal pad can be attached directly to a ground or power plane (whichever is applicable), or alternatively, a special heatsink structure designed into the PCB. This design optimizes the heat transfer from the integrated circuit (IC).

For information on the Quad Flatpack No-Lead (QFN) package and its advantages, refer to Application Report, Quad Flatpack No-Lead Logic Packages, Texas Instruments Literature No. SCBA017. This document is available at [www.ti.com](http://www.ti.com).

The exposed thermal pad dimensions for this package are shown in the following illustration.

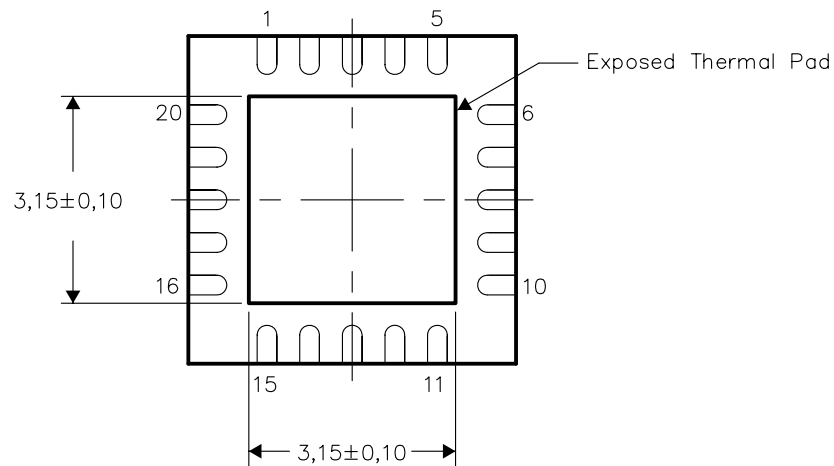

Bottom View

NOTE: All linear dimensions are in millimeters

Exposed Thermal Pad Dimensions

RGW (S-PQFP-N20)

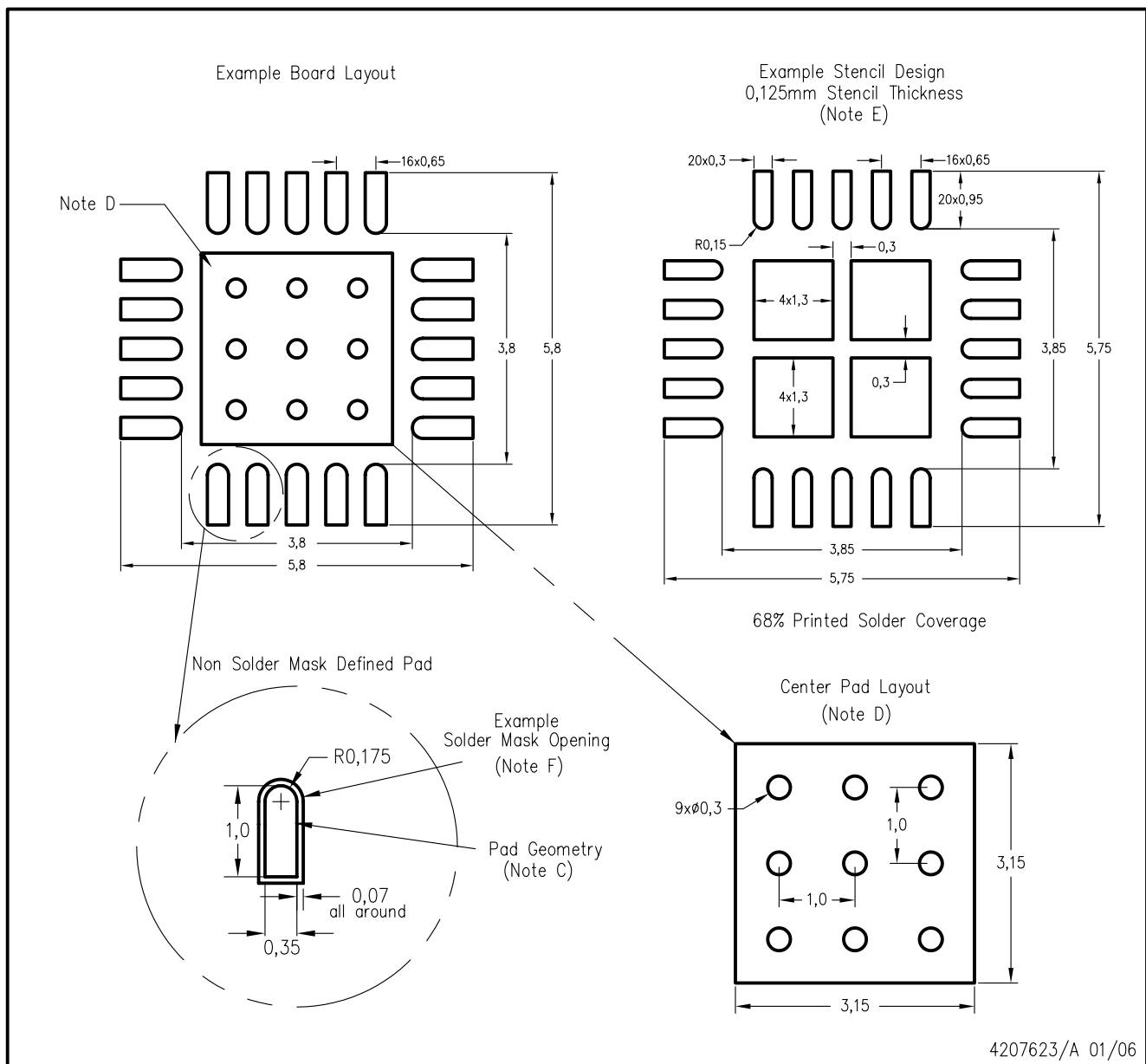

- NOTES:
- All linear dimensions are in millimeters.
  - This drawing is subject to change without notice.
  - Publication IPC-7351 is recommended for alternate designs.
  - This package is designed to be soldered to a thermal pad on the board. Refer to Application Note, QFN Packages, Texas Instruments Literature No. SCBA017, SLUA271, and also the Product Data Sheets for specific thermal information, via requirements, and recommended board layout. These documents are available at [www.ti.com](http://www.ti.com) <<http://www.ti.com>>.
  - Laser cutting apertures with trapezoidal walls and also rounding corners will offer better paste release. Customers should contact their board assembly site for stencil design recommendations. Refer to IPC 7525 for stencil design considerations.
  - Customers should contact their board fabrication site for solder mask tolerances.

## IMPORTANT NOTICE

Texas Instruments Incorporated and its subsidiaries (TI) reserve the right to make corrections, modifications, enhancements, improvements, and other changes to its products and services at any time and to discontinue any product or service without notice. Customers should obtain the latest relevant information before placing orders and should verify that such information is current and complete. All products are sold subject to TI's terms and conditions of sale supplied at the time of order acknowledgment.

TI warrants performance of its hardware products to the specifications applicable at the time of sale in accordance with TI's standard warranty. Testing and other quality control techniques are used to the extent TI deems necessary to support this warranty. Except where mandated by government requirements, testing of all parameters of each product is not necessarily performed.

TI assumes no liability for applications assistance or customer product design. Customers are responsible for their products and applications using TI components. To minimize the risks associated with customer products and applications, customers should provide adequate design and operating safeguards.

TI does not warrant or represent that any license, either express or implied, is granted under any TI patent right, copyright, mask work right, or other TI intellectual property right relating to any combination, machine, or process in which TI products or services are used. Information published by TI regarding third-party products or services does not constitute a license from TI to use such products or services or a warranty or endorsement thereof. Use of such information may require a license from a third party under the patents or other intellectual property of the third party, or a license from TI under the patents or other intellectual property of TI.

Reproduction of TI information in TI data books or data sheets is permissible only if reproduction is without alteration and is accompanied by all associated warranties, conditions, limitations, and notices. Reproduction of this information with alteration is an unfair and deceptive business practice. TI is not responsible or liable for such altered documentation. Information of third parties may be subject to additional restrictions.

Resale of TI products or services with statements different from or beyond the parameters stated by TI for that product or service voids all express and any implied warranties for the associated TI product or service and is an unfair and deceptive business practice. TI is not responsible or liable for any such statements.

TI products are not authorized for use in safety-critical applications (such as life support) where a failure of the TI product would reasonably be expected to cause severe personal injury or death, unless officers of the parties have executed an agreement specifically governing such use. Buyers represent that they have all necessary expertise in the safety and regulatory ramifications of their applications, and acknowledge and agree that they are solely responsible for all legal, regulatory and safety-related requirements concerning their products and any use of TI products in such safety-critical applications, notwithstanding any applications-related information or support that may be provided by TI. Further, Buyers must fully indemnify TI and its representatives against any damages arising out of the use of TI products in such safety-critical applications.

TI products are neither designed nor intended for use in military/aerospace applications or environments unless the TI products are specifically designated by TI as military-grade or "enhanced plastic." Only products designated by TI as military-grade meet military specifications. Buyers acknowledge and agree that any such use of TI products which TI has not designated as military-grade is solely at the Buyer's risk, and that they are solely responsible for compliance with all legal and regulatory requirements in connection with such use.

TI products are neither designed nor intended for use in automotive applications or environments unless the specific TI products are designated by TI as compliant with ISO/TS 16949 requirements. Buyers acknowledge and agree that, if they use any non-designated products in automotive applications, TI will not be responsible for any failure to meet such requirements.

Following are URLs where you can obtain information on other Texas Instruments products and application solutions:

### Products

Amplifiers	<a href="http://amplifier.ti.com">amplifier.ti.com</a>
Data Converters	<a href="http://dataconverter.ti.com">dataconverter.ti.com</a>
DSP	<a href="http://dsp.ti.com">dsp.ti.com</a>
Clocks and Timers	<a href="http://www.ti.com/clocks">www.ti.com/clocks</a>
Interface	<a href="http://interface.ti.com">interface.ti.com</a>
Logic	<a href="http://logic.ti.com">logic.ti.com</a>
Power Mgmt	<a href="http://power.ti.com">power.ti.com</a>
Microcontrollers	<a href="http://microcontroller.ti.com">microcontroller.ti.com</a>
RFID	<a href="http://www.ti-rfid.com">www.ti-rfid.com</a>
RF/IF and ZigBee® Solutions	<a href="http://www.ti.com/lprf">www.ti.com/lprf</a>

### Applications

Audio	<a href="http://www.ti.com/audio">www.ti.com/audio</a>
Automotive	<a href="http://www.ti.com/automotive">www.ti.com/automotive</a>
Broadband	<a href="http://www.ti.com/broadband">www.ti.com/broadband</a>
Digital Control	<a href="http://www.ti.com/digitalcontrol">www.ti.com/digitalcontrol</a>
Medical	<a href="http://www.ti.com/medical">www.ti.com/medical</a>
Military	<a href="http://www.ti.com/military">www.ti.com/military</a>
Optical Networking	<a href="http://www.ti.com/opticalnetwork">www.ti.com/opticalnetwork</a>
Security	<a href="http://www.ti.com/security">www.ti.com/security</a>
Telephony	<a href="http://www.ti.com/telephony">www.ti.com/telephony</a>
Video & Imaging	<a href="http://www.ti.com/video">www.ti.com/video</a>
Wireless	<a href="http://www.ti.com/wireless">www.ti.com/wireless</a>

Mailing Address: Texas Instruments, Post Office Box 655303, Dallas, Texas 75265  
Copyright © 2008, Texas Instruments Incorporated